

# MUFFAKHAM JAH COLLEGE OF ENGINEERING AND TECHNOLOGY

(Affiliated to Osmania University)  
Banjara Hills, Hyderabad, Telangana



DEPARTMENT  
OF  
INFORMATION TECHNOLOGY

**VLSI DESIGN LAB MANUAL**

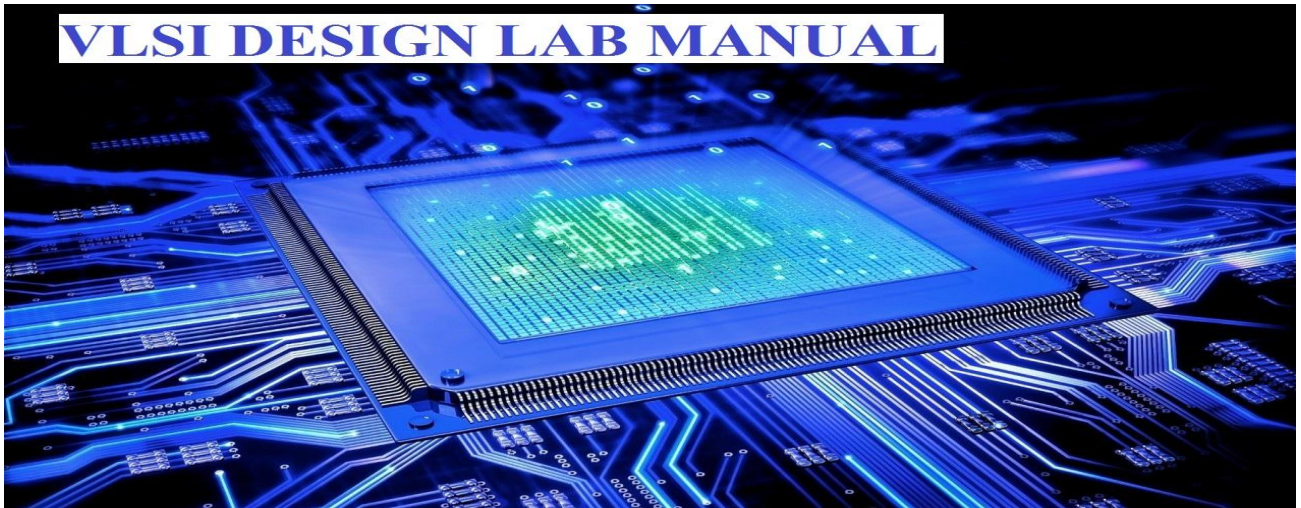

## TABLE OF CONTENTS

S.No.	Content	Page No.	
1.	Institute Vision	i	
2.	Institute Mission	i	
3.	Department Vision	ii	
4.	Department Mission	ii	
5.	PEOs	iii	
6.	POs	iv	
7.	PSOs	v	
8.	General Guidelines and safety instructions	vi	
9.	Introduction to VLSI DESIGN laboratory	vii	
<b>List of Programs</b>			
	<b>List of Programs</b>	<b>Program No.</b>	<b>Page. No</b>
<b>1</b>	<b>SWITCH LEVEL MODELLING</b>		
1.1	OBTAIN LOGIC GATE DESIGN OF NOT , NAND , NOR IN CMOS	1,2,3	1,3,5
1.2	OBTAIN OAI AND AOI LOGIC GATES OF THE FUNCTION		
1.2.1	$F=[ab+ac+bd ]'$ -----AOI	4	7
1.2.2	$F=[(a+b)(a+c)(b+d)]'$ ---OAI	5	9
1.3	TRANSMISSION GATE DESIGN		
1.3.1	2:1 MUX	6	12
1.3.2	XOR GATE	7	14
1.3.3	X-NOR GATE	8	16
1.3.4	OR GATE	9	18
1.4	COMPLEX LOGIC GATES USING CMOS		
1.4.1	$F=[a+b(c+d)]'$	10	21

# VLSI DESIGN LAB MANUAL

---

1.4.2	S-R LATCH	11	23
<b>2</b>	<b>STRUCTURAL GATE LEVEL MODELLING (WITH AND WITHOUT DELAYS)</b>		
2.1	OBTAIN FUNCTION $F=[a+b+ac+bd]'$ using gate level modeling	12	25
2.2	DESIGN HALF ADDER	13	28
2.3	DESIGN FULL ADDER USING 2 HALF ADDER & AN OR GATE	14	31
2.4	IMPLEMENT 2:1 MUX USING TRI STATE BUFFERS	15	34
2.5	IMPLEMENT 4:1 MUX USING 2:1 MULTIPLEXERS	16	37
2.6	SR LATCH	17	40
2.7	D LATCH	18	43
<b>3</b>	<b>HIERARCHICAL MODELING</b>		
3.1	CONSTRUCT A 4 INPUT AND GATE USING 2-INPUT NAND & NOR GATES	19	46
3.2	CONSTRUCT AN 2:4 ACTIVE HIGH DECODER USING CMOS 2-INPUT NOR & NOT GATES	20	48
3.3	SR LATCH	21	50
3.4	D LATCH	22	52
<b>4</b>	<b>RTL &amp; BEHAVIORAL MODELING</b>		
4.1	DESIGN A 4:1 MULTIPLEXER USING RTL & BEHAVIOURAL MODELLING	23	57
14.2	DESIGN A 2:4 ACTIVE HIGH DECODER USING RTL & BEHAVIOURSL MODELLING	24	60
4.3	DESIGN A 4 BIT PRIORITY ENCODER USING RTL & BEHAVIOURSL MODELLING	25	63
4.4	DESIGN A 4 BIT NEGATIVE EDGE TRIGGERED MASTER SLAVE JK FLIP FLOP USING RTL	26	67
4.5	DESIGN A 4 BIT POSTIVE EDGE TRIGGERED MASTER SLAVE D FLIP FLOP USING RTL	27	70

# VLSI DESIGN LAB MANUAL

---

4.6	DESIGN A 4 BIT POSTIVE EDGE TRIGGERED MASTER SLAVE T FLIP FLOP USING RTL	28	72
4.7	DESIGN A 4-BIT LOADABLE SISO/PIPO SHIFT REGISTER USING RTL	29	74
4.8	IMPLEMENT RIPPLE CARRY ADDER USING RTL AND BEHAVIORAL MODELING	30	77
4.9	IMPLEMENT CARRY LOOK AHEAD ADDER USING RTL AND BEHAVIORAL MODELING	31	80
4.10	IMPLEMENT REGISTER MULTIPLIER USING RTL AND BEHAVIORAL MODELING	32	83
4.11	IMPLEMENT ARRAY MULTIPLIER USING RTL MODELING	33	85
5	<b>LAYOUT DESIGNING [DSCH2 &amp; MICROWIND2]</b>		
5.1	OBTAIN LAYOUT DESIGN OF NOT GATE IN CMOS	34	88
5.2	OBTAIN LAYOUT DESIGN OF NAND GATE IN CMOS	35	91
5.3	OBTAIN LAYOUT DESIGN OF NOR GATE IN CMOS	36	93
	ANNEXURE – I OU PRESCRIBED SYLLABUS		95
	ANNEXURE – II PROGRAMMING LAB EVALUATION RUBRIC		96

## **1. Vision of the Institution:**

To be part of universal human quest for development and progress by contributing high calibre, ethical and socially responsible engineers who meet the global challenge of building modern society in harmony with nature.

## **2. Mission of the Institution**

- To attain excellence in imparting technical education from the undergraduate through doctorate levels by adopting coherent and judiciously coordinated curricular and co-curricular programs
- To foster partnership with industry and government agencies through collaborative research and consultancy
- To nurture and strengthen auxiliary soft skills for overall development and improved employability in a multi-cultural work space
- To develop scientific temper and spirit of enquiry in order to harness the latent innovative talents
- To develop constructive attitude in students towards the task of nation building and empower them to become future leaders
- To nourish the entrepreneurial instincts of the students and hone their business acumen.
- To involve the students and the faculty in solving local community problems through economical and sustainable solutions.

### **3. Department Vision**

Fostering a bright technological future by enabling the students to function as leaders in software industry and serve as means of transformation to empower society through ITeS.

### **4. Department Mission**

To create an ambience of academic excellence through state of art infrastructure and learner-centric pedagogy leading to employability in multi-disciplinary fields.

### **5. Programme Education Objectives**

1. Graduates will demonstrate technical competence and leadership in their chosen fields of employment by identifying, formulating, analyzing and creating efficient IT solutions.
2. Graduates will communicate effectively as individuals or team members and be successful in varied working environment.
3. Graduates will demonstrate lifelong learning through continuing education and professional development.
4. Graduates will be successful in providing viable and sustainable solutions within societal, professional, environmental and ethical context

## 6. Programme Outcomes

1. **Engineering knowledge:** Apply the knowledge of mathematics, science, engineering fundamentals and an engineering specialization to the solution of complex engineering problems.
2. **Problem analysis:** Identify, formulate, review research literature, and analyze complex engineering problems reaching substantiated conclusions using first principles of mathematics, natural sciences, and engineering sciences.
3. **Design/development of solutions:** Design solutions for complex engineering problems and design system components or processes that meet the specified needs with appropriate consideration for the public health and safety, and the cultural, societal, and environmental considerations.
4. **Conduct investigations of complex problems:** Use research-based knowledge and research methods including design of experiments, analysis and interpretation of data, and synthesis of the information to provide valid conclusions.
5. **Modern tool usage:** Create, select, and apply appropriate techniques, resources, and modern engineering and IT tools including prediction and modeling to complex engineering activities with an understanding of the limitations.
6. **The engineer and society:** Apply reasoning informed by the contextual knowledge to assess societal, health, safety, legal and cultural issues and the consequent responsibilities relevant to the professional engineering practice.
7. **Environment and sustainability:** Understand the impact of the professional engineering solutions in societal and environmental contexts, and demonstrate the knowledge of, and need for sustainable development.
8. **Ethics:** Apply ethical principles and commit to professional ethics and responsibilities and norms of the engineering practice.
9. **Individual and team work:** Function effectively as an individual, and as a member or leader in diverse teams, and in multidisciplinary settings.
10. **Communication:** Communicate effectively on complex engineering activities with the engineering community and with society at large, such as, being able to comprehend and write effective reports and design documentation, make effective presentations, and give and receive clear instructions.
11. **Project management and finance:** Demonstrate knowledge and understanding of the engineering and management principles and apply these to one's own work, as a member and leader in a team, to manage projects and in multidisciplinary environments.
12. **Lifelong learning:** Recognize the need for, and have the preparation and ability to engage in independent and lifelong learning in the broadest context of technological change.



### 7. Programme Specific Outcomes:

**PSO1:** The IT graduates will work as software engineers for providing solutions to real world problems using structured and object oriented programming languages and open source software.

**PSO2:** The IT graduates will work as System engineer, Software analyst and Tester for IT and ITes.

## MUFFAKHAM JAH COLLEGE OF ENGINEERING AND TECHNOLOGY

### DEPARTMENT OF INFORMATION TECHNOLOGY

#### VLSI DESIGN LAB

#### GENERAL GUIDELINES AND SAFETY INSTRUCTIONS

1. Sign in the log register as soon as you enter the lab.
2. Strictly observe lab timings.
3. Strictly follow the written and verbal instructions given by the teacher / Lab Instructor
4. It is mandatory to come to lab in a formal dress and wear your ID cards.
5. Do not wear loose-fitting clothing or jewelry in the lab.
6. Mobile phones should be switched off in the lab.
7. Keep the labs clean at all times, no food and drinks allowed inside the lab.
8. Do not tamper with computer configurations
9. Playing games on the computers is strictly prohibited.
10. Use of Internet during laboratory timings is prohibited
11. Shut down the computer and switch off the monitor before leaving your table.
12. Handle the Trainer kits with care.
13. Don't plug any external devices / Pen drives without permission from lab staff.
14. Don't install any software without the permission of the Lab Incharge.
15. Observation book and lab record should be carried to each lab.
16. Be sure of location of fire extinguishers and first aid kits in the laboratory.
17. Please take care of your personal belongings. Lab Incharges /Staff are not responsible for any loss of your belongings.

## 8. Introduction TO VLSI DESIGN Laboratory

### Verilog Theory:

Verilog is a **HARDWARE DESCRIPTION LANGUAGE (HDL)**. A hardware description language is a language used to describe a digital system: for example, a network switches, a microprocessor or a memory or a simple flip-flop. This just means that, by using a HDL, one can describe any (digital) hardware at any level. Verilog HDL is **case sensitive**

### Design Styles:

The traditional method of electronic design is bottom-up. Each design is performed at the gate-level using the standard gates. With the increasing complexity of new designs this approach is nearly impossible to maintain. New systems consist of ASIC or microprocessors with a complexity of thousands of transistors. These traditional bottom-up designs have to give way to new structural, hierarchical design methods. Without these new practices it would be impossible to handle the new complexity.

### Bottom-Up Design:

The desired design-style of all designers is the top-down one. A real top-down design allows early testing, easy change of different technologies, a structured system design and offers many other advantages. But it is very difficult to follow a pure top-down design. Due to this fact most designs are a mix of both methods, implementing some key elements of both design styles.

### History of Verilog:

When Cadence gave OVI the LRM, several companies began working on Verilog simulators. In 1992, the first of these were announced, and by 1993 there were several Verilog simulators available from companies other than Cadence. The most successful of these was VCS, the Verilog Compiled Simulator, from Chronologic Simulation. This was a true compiler as opposed to an interpreter, which is what Verilog-XL was. As a result, compile time was substantial, but simulation execution speed was much faster.

Various stages of ASIC/ FPGA IC design flow.

- Specification
- High Level Design
- Micro Design/Low level design
- RTL Coding
- Simulation
- Synthesis
- Place & Route
- Post Silicon Validation

## **Simulation:**

It is the process of verifying the functional characteristics of models at any level of abstraction. We use simulators to simulate the Hardware models, to test if the RTL code meets the functional requirements of the specification. To achieve this we need to write a test bench, which generates clk, reset and the required test vectors. A sample test bench for a counter is shown below. Normally we spend 60-70% of time in design verification.

## **Synthesis:**

It is the process in which synthesis tools like design compiler take RTL in Verilog or VHDL, target technology, and constraints as input and maps the RTL to target technology primitives. Synthesis tool, after mapping the RTL to gates, also do the minimal amount of timing analysis to see if the mapped design is meeting the timing requirements. (Important thing to note is, synthesis tools are not aware of wire delays, they only know of gate delays). After the synthesis there are a couple of things that are normally done before passing the netlist to backend (Place and Route).

## **Place and Route:**

The gate level netlist from the synthesis tool is taken and imported into place and route tool in Verilog netlist format. All the gates and flip-flops are placed; clock tree synthesis and reset is routed. After this each block is routed. The PAR tool output is a GDS file, used by foundry for fabricating the ASIC. Backend team normally dumps out SPEF (standard parasitic exchange format) /RSPF (reduced parasitic exchange format)/DSPF

(detailed parasitic exchange format) from layout tools like ASTRO to the frontend team, who then use the `read_parasitic` command in tools like Prime Time to write out SDF (standard delay format) for gate level simulation purposes.

## Module:

In Verilog, we call our "black boxes" **module**. This is a reserved word within the program used to refer to things with inputs, outputs, and internal logic workings.

- wire data type is used for connecting two points.
- reg data type is used for storing values

Here we have only two types of ports, input and output. In real life, we can have bi-directional ports as well. Verilog allows us to define bi-directional ports as "inout."

## Operators:

Nearly all operators are exactly the same as their counterparts in the C programming language.

## Control Statements:

If-else statements check a condition to decide whether or not to execute a portion of code. If a condition is satisfied, the code is executed. Else, it runs this other portion of code.

One could use any operator in the condition checking, as in the case of C language. If needed we can have nested if else statements; statements without else are also ok, but they have their own problem, when modeling combinational logic, in case they result in a Latch (this is not always true).

Case statements are used where we have one variable which needs to be checked for multiple values. like an address decoder, where the input is an address and it needs to be checked for all the values that it can take. Instead of using multiple nested if-else statements, one for each value we're looking for, we use a single case statement: this is similar to switch statements in languages like C++.

A while statement executes the code within it repeatedly if the condition it is assigned to check returns true. While loops are not normally used for models in real life, but they are used in test benches. As with other statement blocks, they are delimited by begin and end.

For loops in Verilog are almost exactly like for loops in C or C++. The only difference is that the ++ and -- operators are not supported in Verilog.

Repeat is similar to the for loop. Instead of explicitly specifying a variable and incrementing it when we declare the for loop, we tell the program how many times to run through the code, and no variables are incremented.

- While, if-else, case (switch) statements are the same as in C language.
- If-else and case statements require all the cases to be covered for combinational logic.
- For-loop is the same as in C, but no ++ and -- operators.
- Repeat is the same as the for-loop but without the incrementing variable.
- Combinational elements can be modeled using assign and always statements.
- Sequential elements can be modeled using only always statement.
- There is a third block, which is used in test benches only: it is called Initial statement.
- An **initial block**, as the name suggests, is executed only once when simulation starts. This is useful in writing test benches. If we have multiple initial blocks, then all of them are executed at the beginning of simulation.
- **always**: As the name suggests, an always block executes always, unlike initial blocks which execute only once (at the beginning of simulation). A second difference is that an always block should have a sensitive list or a delay associated with it.
- The sensitive list is the one which tells the always block when to execute the block of code. The @ symbol after reserved word 'always', indicates that the block will be triggered "at" the condition in parenthesis after symbol @.
- One important note about always block: it cannot drive wire data type, but can drive reg and integer data types.
- An **assign** statement is used for modeling only combinational logic and it is executed continuously. So the assign statement is called 'continuous assignment statement' as there is no sensitive list.

## Tasks and Functions:

When repeating the same old things again and again, Verilog, like any other programming language, provides means to address repeated used code, these are called Tasks and Functions.

Functions and tasks have the same syntax; one difference is that tasks can have delays, whereas functions can not have any delay. This means that function can be used for modeling combinational logic.

A second difference is that functions can return a value, whereas tasks cannot.

## Module Instantiation

- Modules are the building blocks of Verilog designs
- You create the design hierarchy by instantiating modules in other modules.
- You instance a module when you use that module in another, higher-level module
- **Ports:** Ports allow communication between a module and its environment.
- All but the top-level modules in a hierarchy have ports.
- Ports can be associated by order or by name.
- **Registers:** store the last value assigned to them until another assignment statement changes their value.
- Registers represent data storage constructs.
- We can create regs arrays called memories.
- Register data types are used as variables in procedural blocks.
- Register data type is required if a signal is assigned a value within a procedural block
- Procedural blocks begin with keyword initial and always.

## Gate level primitives:

- Verilog has built in primitives like gates, transmission gates, and switches. These are rarely used in design (RTL Coding), but are used in post synthesis step for modeling the ASIC/FPGA cells; these cells are then used for gate level simulation, or what is called as SDF simulation. Also the output netlist format from the synthesis tool, which is imported into the place and route tool, is also in Verilog gate level primitives. Ex: and , or etc:

- There are six different switch primitives (transistor models) used in Verilog, nmos, pmos and cmos and the corresponding three resistive versions rnmos, rpmos and rcmos. The cmos types of switches have two gates and so have two control signals.
- Transmission gates tran and rtran are permanently on and do not have a control line. Tran can be used to interface two wires with separate drives, and rtran can be used to weaken signals. Resistive devices reduce the signal strength which appears on the output by one level. All the switches only pass signals from source to drain; incorrect wiring of the devices will result in high impedance outputs.

### **Delays:**

In real circuits, logic gates have delays associated with them. Verilog provides the mechanism to associate delays with gates

- Rise, Fall and Turn-off delays.
- Minimal, Typical, and Maximum delays.
- In Verilog delays can be introduced with `#'num'` as in the examples below, where `#` is a special character to introduce delay, and `'num'` is the number of ticks simulator should delay current statement execution
- The rise delay is associated with a gate output transition to 1 from another value (0, x, z).
- The fall delay is associated with a gate output transition to 0 from another value (1, x, z).
- The Turn-off delay is associated with a gate output transition to z from another value (0, 1, x).
- The min value is the minimum delay value that the gate is expected to have.
- The typ value is the typical delay value that the gate is expected to have.
- The max value is the maximum delay value that the gate is expected to have.

### **User Defined Primitives (UDP):**

Verilog has built-in primitives like gates, transmission gates, and switches. This is a rather small number of primitives; if we need more complex primitives, then Verilog provides UDP, or simply User Defined Primitives. Using UDP we can model.



- Combinational Logic
- Sequential Logic

UDP begins with reserve word **primitive** and ends with **endprimitive**. Ports/terminals of primitive should follow. This is similar to what we do for module definition. UDPs should be defined outside **module** and **endmodule**.

## UDP port rules:

- An UDP can contain only one output and up to 10 inputs.
- Output port should be the first port followed by one or more input ports.
- All UDP ports are scalar, i.e. Vector ports are not allowed.
- UDPs cannot have bidirectional ports.
- The output terminal of a sequential UDP requires an additional declaration as type reg.
- It is illegal to declare a reg for the output terminal of a combinational UDP.
- Functionality of primitive (both combinational and sequential) is described inside a table, and it ends with reserved word 'endtable'. For sequential UDP, we can use initial to assign an initial value to output.

**Note:** An UDP cannot use 'z' in the input table

**table:** It is used for describing the function of UDP. Verilog reserved word **table** marks the start of table and reserved word **endtable** marks the end of table. Each line inside a table is one condition; when an input changes, the input condition is matched and the output is evaluated to reflect the new change in input.

**initial:** This statement is used for initialization of sequential UDPs. This statement begins with the keyword 'initial'. The statement that follows must be an assignment statement that assigns a single bit literal value to the output terminal reg.

- Concatenations: are expressed using the brace characters { & }, with commas separating the expressions within.
  - Example: + {a, b[3:0], c, 4'b1001} // if a and c are 8-bit numbers, the results has 24 bits
- Unsized constant numbers are not allowed in concatenations.

## Abstraction Levels:

- Behavioral Models: Higher level of modeling where behavior of logic is modeled.
- RTL Models : Logic is modeled at register level
- Structural Models: Logic is modeled at both register level and gate level.

## Procedural Blocks:

Verilog behavioral code is inside procedure blocks, but there is an exception: some behavioral code also exist outside procedure blocks.

- **initial:** initial blocks execute only once at time zero (start execution at time zero).
- **always:** always blocks loop to execute over and over again; in other words, as the name suggests, it executes always.

## Procedural Assignment Statements:

- Procedural assignment statements assign values to reg, integer, real, or time variables and cannot assign values to nets (wire data types)

## Procedural Group Statements:

If a procedure block contains more than one statement, those statements must be enclosed within

- Sequential **begin - end** block
- Parallel **fork - join** block

When using begin-end, we can give name to that group. This is called **named blocks**

### **begin - end**

- Group several statements together.
- Cause the statements to be evaluated sequentially (one at a time)
- Any timing within the sequential groups is relative to the previous statement.
- Delays in the sequence accumulate (each delay is added to the previous delay)
- Block finishes after the last statement in the block

### **fork - join**

- Group several statements together.
- Cause the statements to be evaluated in parallel (all at the same time).
- Timing within parallel group is absolute to the beginning of the group.
- Block finishes after the last statement completes (Statement with highest delay, it can be the first statement in the block).

### **Blocking and Nonblocking Assignment Statements:**

- Blocking assignments are executed in the order they are coded, hence they are sequential. Since they block the execution of next statement, till the current statement is executed, they are called blocking assignments. Assignment are made with "=" symbol.

Example a = b;

- Nonblocking assignments are executed in parallel. Since the execution of next statement is not blocked due to execution of current statement, they are called nonblocking statement. Assignments are made with "<=" symbol. Example a <= b;

### **assign and deassign:**

- The assign and deassign procedural assignment statements allow continuous assignments to be placed onto registers for controlled periods of time. The assign procedural statement overrides procedural assignments to a **register**. The deassign procedural statement ends a continuous assignment to a register.

### **force and release:**

- Another form of procedural continuous assignment is provided by the force and release procedural statements. These statements have a similar effect on the assign-deassign pair, but a force can be applied to nets as well as to registers. One can use force and release while doing gate level simulation to work around reset connectivity problems. Also can be used insert single and double bit errors on data read from memory.

## **Casex and casez:**

- Special versions of the case statement allow the x and z logic values to be used as "don't care".

## **Looping statements:**

- Appear inside procedural blocks only; Verilog has four looping statements like any other programming language.
- The forever loop executes continually, the loop never ends. Normally we use forever statements in initial blocks.
- The repeat loop executes < statement > a fixed < number > of times
- The while loop executes as long as an < expression > evaluates as true. This is the same as in any other programming language.
- The for loop is the same as the for loop used in any other programming language.
- Continuous assignment statements drive nets (wire data type). They represent structural connections.

## 1. SWITCH LEVEL MODELLING

### Program 1

#### 1.1 OBTAIN LOGIC GATE DESIGN OF NOT, NAND, NOR IN CMOS

**Aim:-**

Design a logic gate in CMOS

**Software Requirements:**

Synthesis tool:	Xilinx Project navigator – ISE 14.7
Simulation tool:	ModelSim Simulator

**Description:** Digital logic circuits are non linear networks that use transistors as electronic switches to divert one of the supply voltages  $V_{DD}$  or  $0V$  to the output. This corresponds to a logic result of  $f=1$  or  $f=0$ .

An important characteristic of a CMOS circuit is the duality that exists between its PMOS transistors and NMOS transistors. According to the De Morgan's laws based logic, the PMOS transistors in parallel have corresponding NMOS transistors in series while the PMOS transistors in series have corresponding NMOS transistors in parallel.

The NOT or the INVERT function is the simplest Boolean operation. It has an input 'a' and produces output  $f(a)$  i.e. it implements logical negation.

An important feature of CMOS is the manner in which complementary FET pair ensures that always a path from the output to either the power source  $V_{DD}$  or ground. To accomplish this, the set of all paths to the voltage source must be the complement of the set of all paths to ground. This can be easily accomplished by defining one in terms of the NOT of the other.

**LOGIC SYMBOL**

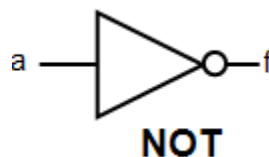

## TRUTH TABLE

a	F
0	1
1	0

## LOGIC DIAGRAM

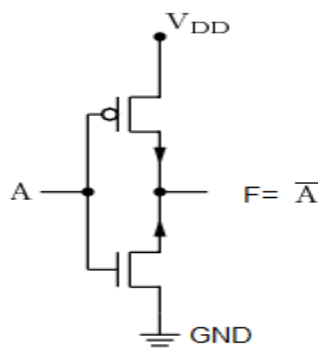

## VERILOG CODE

```
module not1(a,f);  
  input a;  
  output f;  
  supply1 vdd;  
  supply0 gnd;  
  pmos p(f,vdd,a);  
  nmos n(f,gnd,a);  
endmodule
```

## OUTPUT

The Truth Table of not gate is verified.

## Program 2 OBTAIN LOGIC GATE DESIGN OF NAND IN CMOS

### Aim:-

Write Verilog code for two input logic gates

### Software Requirements:

Synthesis tool:	Xilinx Project navigator – ISE 14.7
Simulation tool:	ModelSim Simulator

**Description:** Digital logic circuits are non linear networks that use transistors as electronic switches to divert one of the supply voltages  $V_{DD}$  or  $0V$  to the output. This corresponds to a logic result of  $f=1$  or  $f=0$ .

An important characteristic of a CMOS circuit is the duality that exists between its PMOS transistors and NMOS transistors. According to the De Morgan's laws based logic, the PMOS transistors in parallel have corresponding NMOS transistors in series while the PMOS transistors in series have corresponding NMOS transistors in parallel.

A NAND2 gate is that it uses two parallel connected pFET's while the nFET's are in series. The NAND gate is characterized by an output that is 0 unless both of the inputs are 1.

In a two-input CMOS NAND (NAND2) gate the two series connected nMOS transistors creates a conducting path between output node and the ground only if both input voltages are set to  $V_{OH}$  i.e. both the parallel pMOS transistors will be off. For all other input combinations, either one or both of the pMOS transistors will be turned on, while the path of the nMOS transistors will be cut-off, thus creating a current path between the output node and the power supply voltage.

### LOGIC SYMBOL



## TRUTH TABLE

A	B	F
0	0	1
0	1	1
1	0	1
1	1	0

## LOGIC DIAGRAM

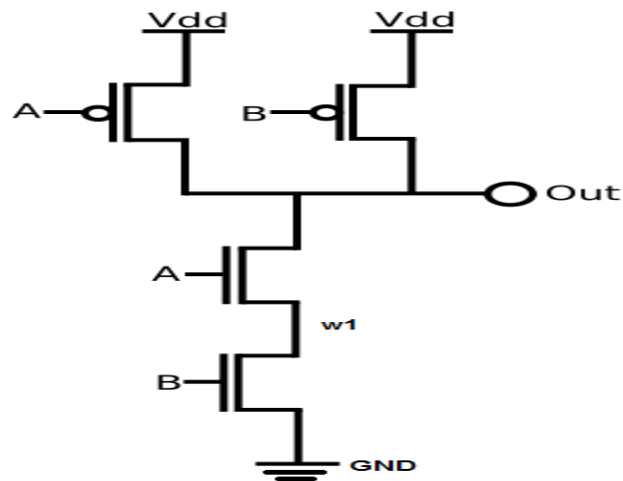

## VERILOG CODE

```
module cmosnand(f,a,b);
input a;
input b;
output f;
wire w1;
supply1 vdd;
supply0 gnd;
pmos p1(f,vdd,a);
pmos p2(f,vdd,b);
nmos n1(f,w1,a);
nmos n2(w1,gnd,b);
endmodule
```

## OUTPUT:

The Truth Table of NAND gate is verified.



## Program 3 OBTAIN LOGIC GATE DESIGN OF NOR IN CMOS

### Aim:-

- Write Verilog code for two input logic gates

### Software Requirements:

Synthesis tool:	Xilinx Project navigator – ISE 14.7
Simulation tool:	ModelSim Simulator

**Description:** An important characteristic of a CMOS circuit is the duality that exists between its PMOS transistors and NMOS transistors. According to the De Morgan's laws based logic, the PMOS transistors in parallel have corresponding NMOS transistors in series while the PMOS transistors in series have corresponding NMOS transistors in parallel.

The NOR gate has 2 PMOS and 2 NMOS transistors. It uses two parallel connected nFET's while the pFET's are in series. The NOR gate is characterized by an output 1 only if both of the inputs are 1.

When either one or both inputs are high, the nMOS transistor(s) creates a conducting path between the output node and ground, and the pMOS transistors are cut-off i.e  $f = 0v$ .. When both input voltages are low, the nMOS transistors are cut-off and the pMOS transistors create a conducting path between the output node and the supply voltage VDD thus giving output high.

### LOGIC SYMBOL

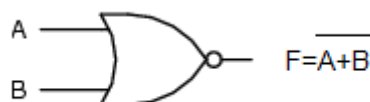

### TRUTH TABLE

A	B	F
0	0	1
0	1	0
1	0	0
1	1	0

## LOGIC DIAGRAM

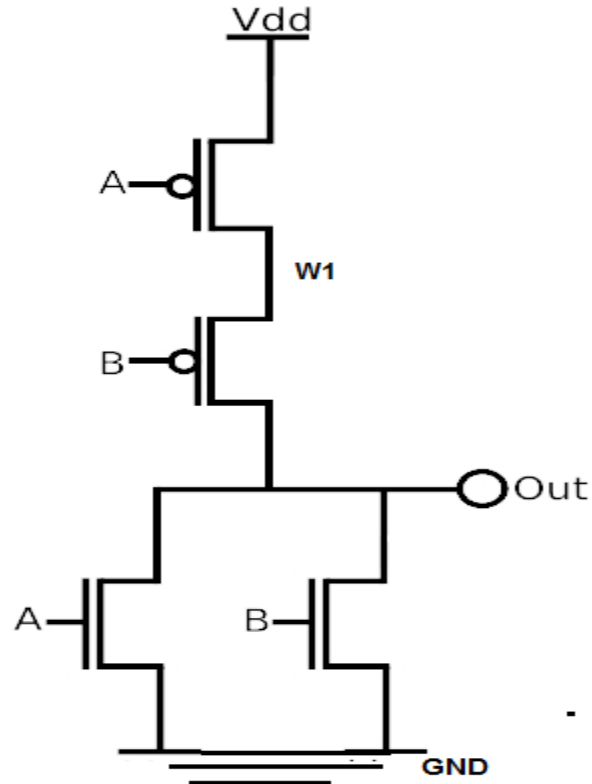

## VERILOG CODE

```
module cmosnor(x,a,b);  
    input a;  
    input b;  
    output f;  
    wire w1;  
    supply1 vdd;  
    supply0 gnd;  
    pmos p1(w1,vdd,a);  
    pmos p2(f,w1,b);  
    nmos n1(f,gnd,a);  
    nmos n2(f,gnd,b);
```

endmodule

## OUTPUT:

The Truth Table of NOR gate is verified.

**Program 4**

**1.2 OBTAIN OAI AND AOI LOGIC GATES OF THE FUNCTION**

**12.1  $F=[ab+ac+bd ]'$ -----AOI**

**Aim:-**

Write Verilog code for AOI  $F=[ab+ac+bd ]'$

**Software Requirements:**

Synthesis tool:	Xilinx Project navigator – ISE 14.7
Simulation tool:	ModelSim Simulator

**Description:** An important characteristic of a CMOS circuit is its inverting nature which allows it to construct logic circuits for AOI logic expression using a structured approach.

AOI gates perform one or more AND operations followed by an OR operation and then an inversion. AOI function is an inverted sum of products ISOP

Construction of AOI cells is particularly efficient using CMOS technology where the total number of transistor gates can be compared to the same construction using NAND logic or NOR logic. The complement of AOI Logic is OR-AND-Invert (OAI) logic where the OR gates precede a NAND gate.

**LOGIC SYMBOL**

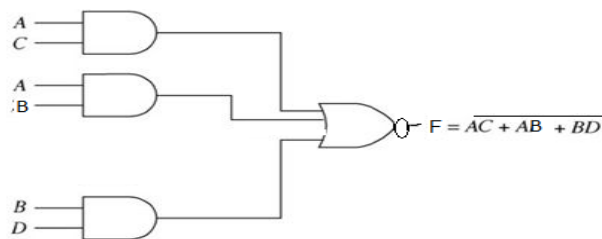

**TRUTH TABLE**

A	B	C	D	F
0	0	0	0	1
0	1	0	1	0
1	0	1	0	0
1	1	0	0	0
1	1	1	1	0

## LOGIC DIAGRAM

$$F = ab + bd + ca$$

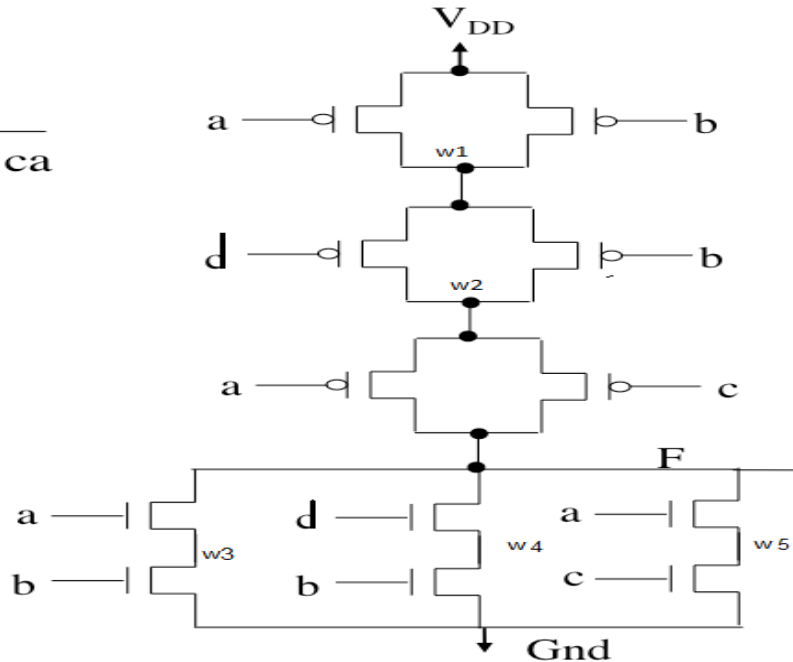

## VERILOG CODE

```

module aoi(a,b,c,d,f);
    input a;
    input b;
    input c;
    input d;
    output f;
    supply1 vdd;
    supply0 gnd;
    wire w1,w2,w3,w4,w5;
    pmos p1(w1,vdd,a);
    pmos p2(w1,vdd,b);
    pmos p3(w2,w1,a);
    pmos p4(w2,w1,c);
    pmos p5(f,w2,b);
    pmos p6(f,w2,d);
    nmos n1(w3,gnd,b);
    nmos n2(f,w3,a);
    nmos n3(w4,gnd,c);
    nmos n4(f,w4,a);
    nmos n5(w5,gnd,d);
    nmos n6(f,w5,b);
endmodule

```

## OUTPUT:

The Truth Table of AOI is verified.

## Program 5

### 1.2.2 $F = [(a+b)(a+c)(b+d)]'$ ---OAI

**AIM:-**

Write Verilog code for AOI  $F = [(a+b)(a+c)(b+d)]'$

#### SOFTWARE REQUIREMENTS:

Synthesis tool:	Xilinx Project navigator – ISE 14.7
Simulation tool:	ModelSim Simulator

**DESCRIPTION:** CMOS logic gates are intrinsically inverting. The output always produces a NOT operation acting on the input variables. The inverting nature of CMOS logic circuits allows us to construct logic circuits for AOI and OAI expressions using a structured approach.

OAI logic function implements the operations in the order OR then AND then NOT. An Or-And-Invert (OAI) CMOS gate is similar to the AOI gate except that it is an implementation of product-of-sums realization of a function

Behaviors of nMOS and pMOS groups are Parallel-connected nMOS gives OR-NOT operations whereas Parallel-connected pMOS gives AND-NOT operations Series-connected nMOS results AND-NOT operations whereas Series-connected pMOS gives OR-NOT.

The OAI are implemented in the following way:

- The N-tree is implemented as follows:
  - Each product term is a set of parallel transistors for each input in the term
  - All product terms (parallel groups) are put in series
  - The complete function is again assumed to be an inverted representation
- The P-tree can be implemented as the dual of the N-tree

#### LOGIC SYMBOL

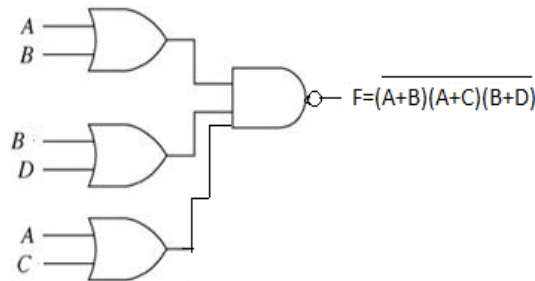

## TRUTH TABLE

A	B	C	D	F
0	0	0	0	1
0	1	0	1	1
0	1	1	1	0
1	1	0	0	1
1	1	1	1	0

## LOGIC DIAGRAM

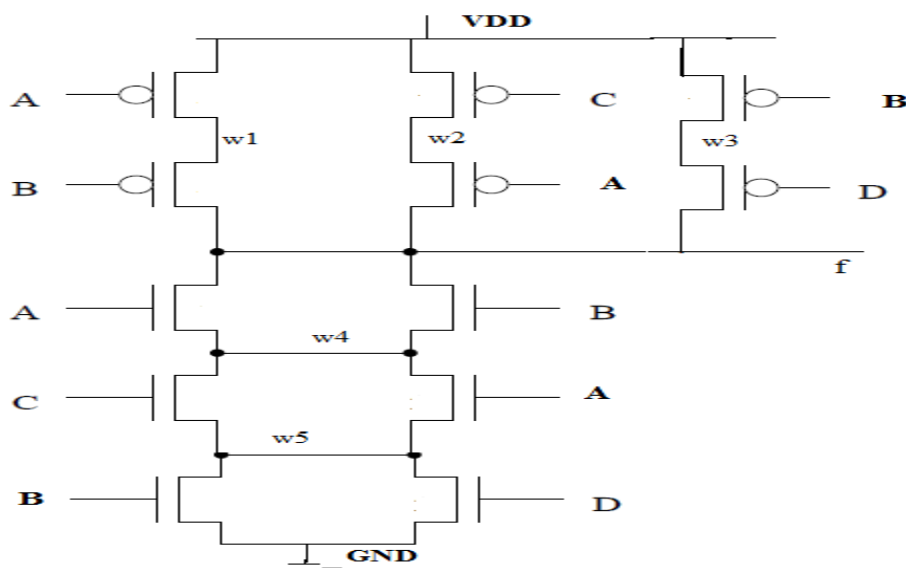

## VERILOG CODE

```

module oai(a,b,c,d,f);
    input a;
    input b;
    input c;
    input d;
    output f;
    supply1 vdd;
    supply0 gnd;
    wire w1,w2,w3,w4,w5;
    pmos p1(w3,vdd,a);
    pmos p2(f,w3,b);
    pmos p3(w4,vdd,a);
    pmos p4(f,w4,c);
    pmos p5(w5,vdd,b);
    pmos p6(f,w5,d);
    nmos n1(w1,gnd,b);

```

```
nmos n2(w1,gnd,d);  
nmos n3(w2,w1,a);  
nmos n4(w2,w1,c);  
nmos n5(f,w2,a);  
nmos n6(f,w2,b);  
endmodule
```

### **OUTPUT:**

The Truth Table of OAI is verified.

## Program 6

### 1.3 TRANSMISSION GATE DESIGN

#### 1.3.1 Design a 2:1 MUX using TRANSMISSION GATE

#### Aim:-

Write Verilog code for 2:1 mux using Transmission gates.

#### Software Requirements:

Synthesis tool:	Xilinx Project navigator – ISE 14.7
Simulation tool:	ModelSim Simulator

**Description:** A CMOS Transmission gate is created by connecting an nFET and pFET in parallel. It has the following characteristics.

- » It is a Bi-directional switch
- » It Transmit the entire voltage range  $[0, V_{DD}]$
- » Both transistors are ON or OFF simultaneously.
- » The NMOS switch passes a good zero but a poor 1.
- » The PMOS switch passes a good one but a poor 0.

Controlled by gate select signals,  $s$  and  $\bar{s}$

–if  $s = 1$ ,  $y = x$ , switch is **closed**, transistors are **on**

– if  $s = 0$ ,  $y = \text{unknown}$  (high impedance), switch **open**, transistors are **off**

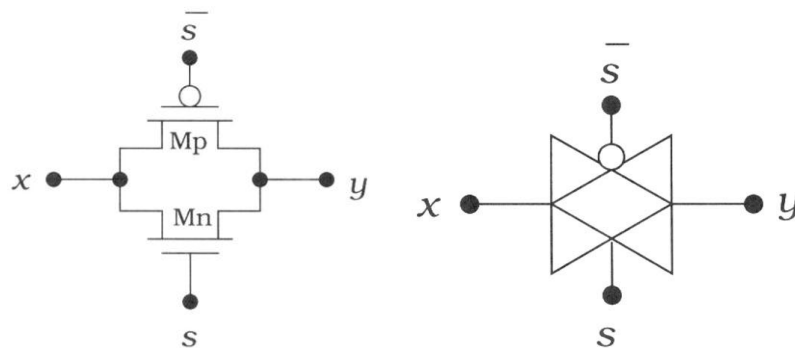

In 2:1 mux when the select signal has a value  $s=0$ , one pair of Transmission gate is closed while other is open giving the first input as output but if  $s=1$  the second input goes as output.



## LOGIC SYMBOL

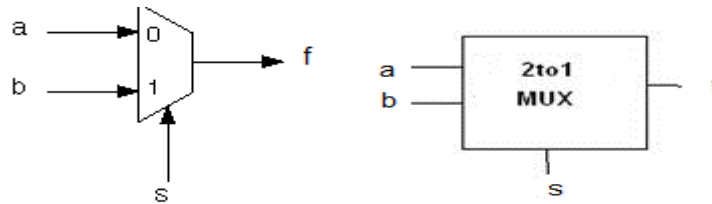

## TRUTH TABLE

s	F
0	A
1	B

## LOGIC DIAGRAM

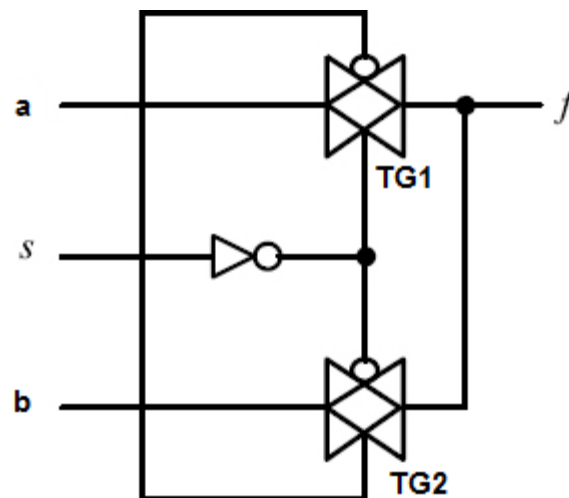

## VERILOG CODE

```
module mux(a,b,s,f);
    input a;
    input b;
    input s;
    output f;
    wire sb;
    not(sb,s);
    cmos tg1(f,a,sb,s);
    cmos tg2(f,b,s,sb);
endmodule
```

**OUTPUT:** The Truth Table of TRANSMISSION GATE is verified.

## Program 7

### 1.3.2 Design a XOR using TRANSMISSION GATE

#### Aim:-

Write Verilog code for XOR using transmission gate

#### Software Requirements:

Synthesis tool:	Xilinx Project navigator – ISE 14.7
Simulation tool:	ModelSim Simulator

**Description:** A CMOS Transmission gate is created by connecting an nFET and pFET in parallel. It has the following characteristics.

- » It is a Bi-directional switch
- » It Transmit the entire voltage range  $[0, V_{DD}]$
- » Both transistors are ON or OFF simultaneously.
- » The NMOS switch passes a good zero but a poor 1.
- » The PMOS switch passes a good one but a poor 0.

Controlled by gate select signals,  $s$  and  $\bar{s}$

--if  $s = 1$ ,  $y = x$ , switch is **closed**, transistors are **on**

-- if  $s = 0$ ,  $y = \text{unknown}$  (high impedance), switch **open**, transistors are **off**

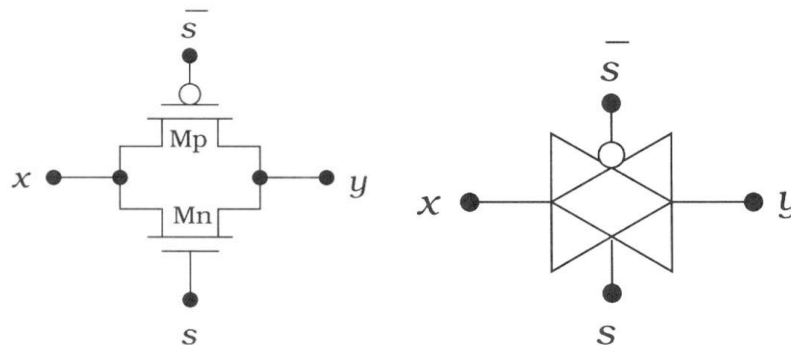

In XOR gate implementation of transmission gate the input to the top transmission gate is  $b$ , this is inverted and given as input to the second TG. The input 'a' and its complement are used to control the TGs. When  $a=0$  the upper TG is closed and 'b' is passed to the output while  $a=1$  closes the lower TG is closed and 'b' complement is passed to the output.

## LOGIC SYMBOL



## TRUTH TABLE

A	B	$A \oplus B$
0	0	0
0	1	1
1	0	1
1	1	0

## LOGIC DIAGRAM

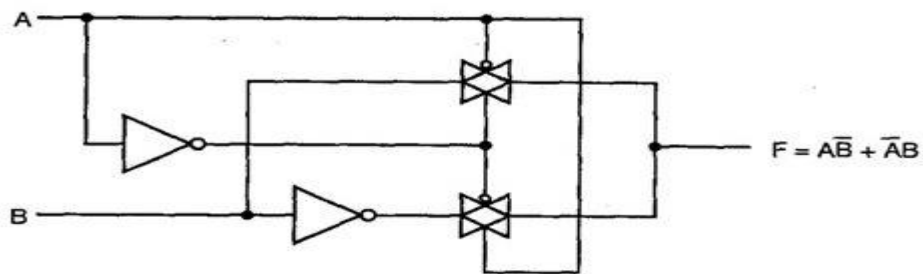

## VERILOG CODE

```
module xortg(a,b,f);
  input a;
  input b;
  output f;
  wire ab,bb;
  not(ab,a);
  not(bb,b);
  cmos tg1(f,b,ab,a);
  cmos tg2(f,bb,a,ab);
endmodule
```

## OUTPUT:

The Truth Table of XOR TRANSMISSION GATE is verified.

## Program 8

### 1.3.3 Design a XNOR gate using TRANSMISSION GATE

#### Aim:-

- a) Write Verilog code for XNOR using transmission gate

#### Software Requirements:

Synthesis tool:	Xilinx Project navigator – ISE 14.7
Simulation tool:	ModelSim Simulator

**Description:** A CMOS Transmission gate is created by connecting an nFET and pFET in parallel. It has the following characteristics.

- » It is a Bi-directional switch
- » It Transmit the entire voltage range  $[0, V_{DD}]$
- » Both transistors are ON or OFF simultaneously.
- » The NMOS switch passes a good zero but a poor 1.
- » The PMOS switch passes a good one but a poor 0.

Controlled by gate select signals,  $s$  and  $\bar{s}$

–if  $s = 1$ ,  $y = x$ , switch is **closed**, transistors are **on**

– if  $s = 0$ ,  $y = \text{unknown}$  (high impedance), switch **open**, transistors are **off**

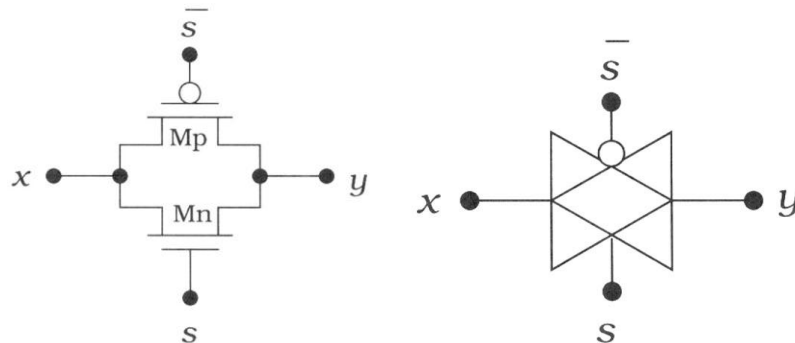

An XNOR gate function is obtained by interchanging 'b' and its compliment  $\bar{b}$  from XOR functions. The output of an XNOR gate is 1 iff the inputs are equal. In XNOR implementation of transmission gate the input to the top transmission gate is ' $\bar{b}$ ', this is inverted and given as input to the second TG. The input 'a' and its compliment are used to control the TGs. When  $a=0$  the upper TG is closed and ' $\bar{b}$ ' is passed to the output while  $a=1$  closes the lower TG is closed and ' $b$ ' is passed to the output.

## LOGIC SYMBOL

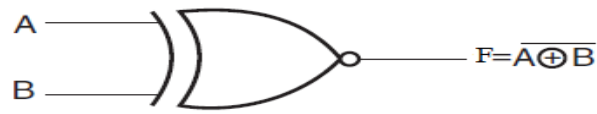

$$F = \overline{(A \oplus B)} = (A.B + \overline{A}.\overline{B})$$

## TRUTH TABLE

## LOGIC DIAGRAM

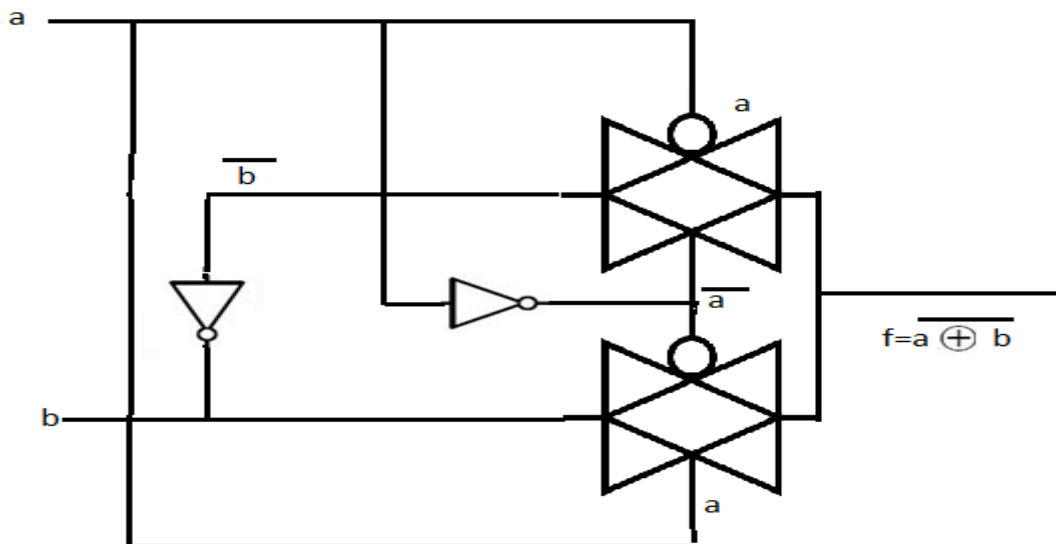

## VERILOG CODE

```
module xnor1(a,b,f);
  input a;
  input b;
  output f;
  wire aa,bb;
  not(ab,a);
  not(bb,b);
  cmos tg1(f,b,a,ab);
  cmos tg2(f,bb,ab,a);
endmodule
```

**OUTPUT:** The Truth Table of XNOR TRANSMISSION GATE is verified.

## Program 9

### 1.3.4 Design a OR gate using TRANSMISSION GATE

#### Aim:-

- b) Write Verilog code for OR using transmission gate

#### Software Requirements:

Synthesis tool:	Xilinx Project navigator – ISE 14.7
Simulation tool:	ModelSim Simulator

**Description:** A CMOS Transmission gate is created by connecting an nFET and pFET in parallel. It has the following characteristics.

- » It is a Bi-directional switch
- » It Transmit the entire voltage range  $[0, V_{DD}]$
- » Both transistors are ON or OFF simultaneously.
- » The NMOS switch passes a good zero but a poor 1.
- » The PMOS switch passes a good one but a poor 0.

Controlled by gate select signals,  $s$  and  $\bar{s}$

--if  $s = 1$ ,  $y = x$ , switch is **closed**, transistors are **on**

-- if  $s = 0$ ,  $y = \text{unknown}$  (high impedance), switch **open**, transistors are **off**

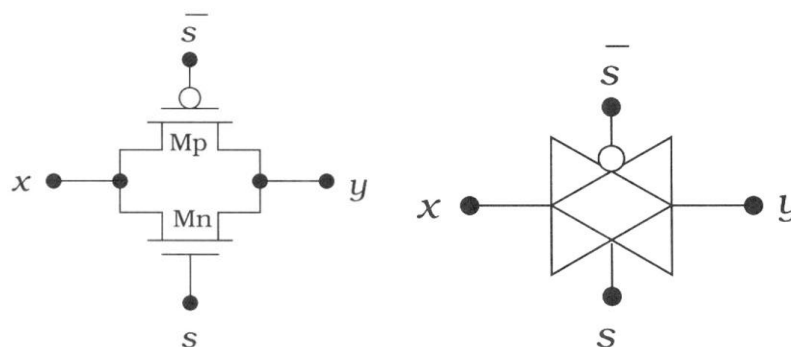

In OR implementation of transmission gate the input to the top transmission gate is 'b,' and to the second TG2 is 'a'. The input 'a' and its complement are used to control the TGs. When  $a=0$  the upper TG is closed and 'b' is passed to the output while  $a=1$  closes the lower TG and 'a' is passed to the output.

## LOGIC SYMBOL

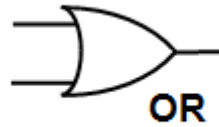

## TRUTH TABLE

Inputs		Output
A	B	F
0	0	0
1	0	1
0	1	1
1	1	1

## LOGIC DIAGRAM

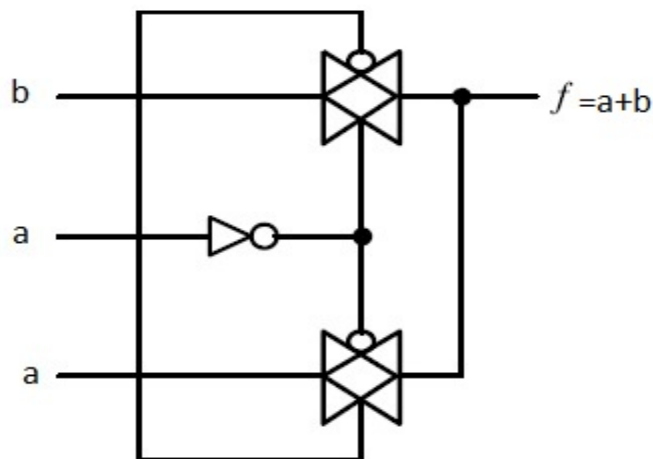

## VERILOG CODE

```
module or1(a,b,f);
  input a;
  input b;
  output f;
  wire ab;
  not(ab,a);
  cmos tg1(f,b,ab,a);
  cmos tg2(f,a,a,ab);
endmodule
```

## OUTPUT:

The Truth Table of OR TRANSMISSION GATE is verified.



## Program 10

### 1.4 COMPLEX LOGIC GATES USING CMOS

1.4.1  $F=[a+b(c+d)]'$

**Aim:-**

Design  $F=[a+b(c+d)]'$  using CMOS

**Software Requirements:**

Synthesis tool:	Xilinx Project navigator – ISE 14.7
Simulation tool:	ModelSim Simulator

**Description:** Complex or combinational logic gates are useful in VLSI system-level design. Complex gates can be realized at transistor level – which is advantageous as the gate delay is smaller for one complex gate than for the series connection of several simple gates realizing the same function.

The realized logic function can be any combination of the NOT, AND, OR functions and there is always an inversion at the output

Simplest way to construct is to use the PDN and PUN .First the pull-down network (PDN) is created. The OR function is realized by n-type FETs connected in parallel. The AND function is realized by n-type FETs connected in series.

Next the pull-up network (PUN) is designed with p-type transistors. The PUN has to create a current path between the supply rail and the output for every logic 1 of the logic function. This can be done by creating the dual network of the PDN. In the dual network every series connection is turned into a parallel connection and vica versa.

**LOGIC SYMBOL**

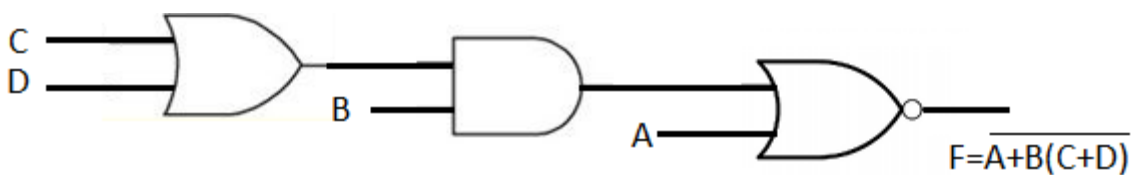

## TRUTH TABLE

A	B	C	D	F
0	0	0	0	1
0	1	0	0	0
1	0	1	0	0
1	1	1	1	0

## LOGIC DIAGRAM

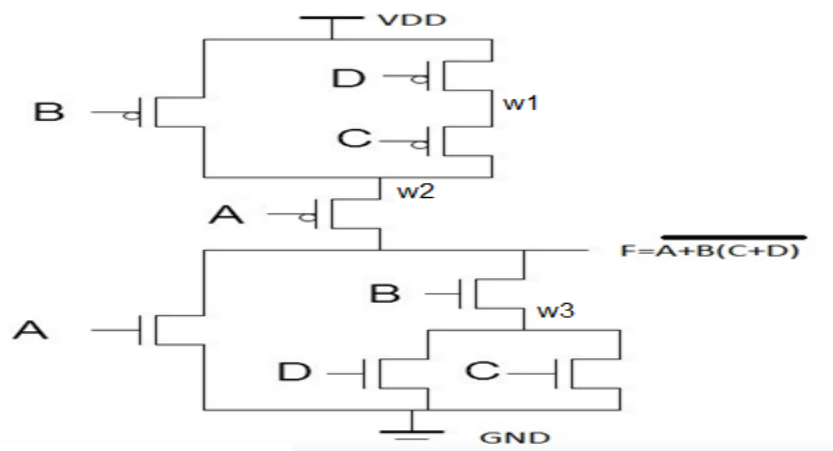

## VERILOG CODE

```
module complex(a,b,c,d,f);
    input a;
    input b;
    input c;
    input d;
    output f;
    wire w1,w2,w3;
    supply0 gnd;
    supply1 vdd;
    pmos p1(w2,vdd,b);
    pmos p2(w1,vdd,c);
    pmos p3(w2,w1,d);
    pmos p4(f,w2,a);
    nmos n1(w3,gnd,c);
    nmos n2(w3,gnd,d);
    nmos n3(f,w3,b);
    nmos n4(f,gnd,a);
endmodule
```

**OUTPUT:** The Truth Table of COMS complex logic is verified.

## Program 11

1.4.2 Write Verilog code for SR Latch using CMOS

### Aim:-

Design SR Latch using CMOS

### Software Requirements:

Synthesis tool:	Xilinx Project navigator – ISE 14.7
Simulation tool:	ModelSim Simulator

**Description:** A latch (also called a **flip-flop**) is a fundamental component of **data storage**. A single latch can hold 1-bit of data, increase that number by *many* orders of magnitude and you can create kilo-, mega-, giga-, even tera-bytes of memory

The logic diagram for SR latch can be obtained by using two NOR2 gates. The two NOR gates each have their output flow into the input of the other. There are two controllable inputs: reset (R) and set (S), which produce the two outputs: Q and Q(“Q-not”). That’s where the SR latch gets its name – it’s a **set/reset** latch.

- **Steady:** When S and R are both 0, then Q remains steady. It keeps the value it had before. If it was 0 it’ll remain 0, if it was 1 it will still be 1.
- **Set:** Changing S to 1 has the potential to “set” the output of Q. If Q was 0, changing S to 1 will change Q to 1 as well. If Q was already 1, making S=1 will have no effect.
- **Reset:** Moving the R input from 0 to 1 can “reset” Q. As long as Q *was* 1, setting R to 1 will change Q to 0. If Q was already 0, though, R won’t have any effect on it.
- **Restricted:** When **both S and R are 1**, we enter restricted territory: our rule that Q and Q must be complements is broken, as they both go to 0. So we call S=1/R=1 a restricted combination. In most latch circuits precautions are taken to keep those inputs from both being 1.

### LOGIC SYMBOL

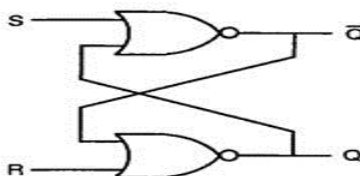

## TRUTH TABLE

S	R	$Q_{n+1}$	$\overline{Q}_{n+1}$	Operation
0	0	$Q_n$	$\overline{Q}_n$	hold
1	0	1	0	set
0	1	0	1	reset
1	1	0	0	not allowed

## LOGIC DIAGRAM

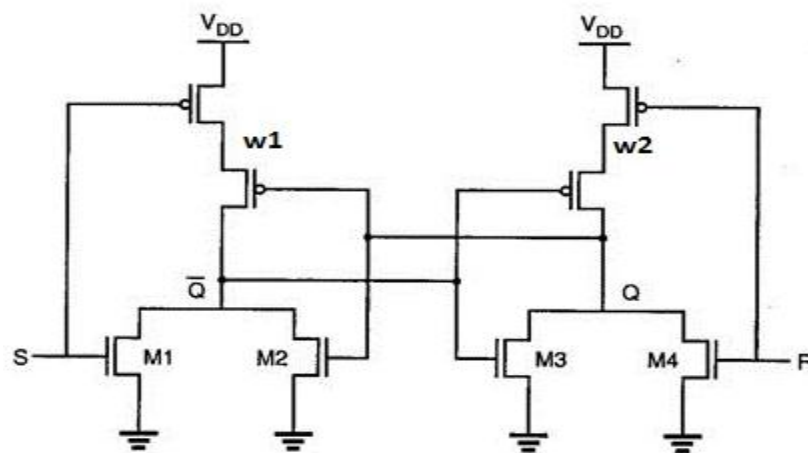

## VERILOG CODE

```

module srlatch(s,r,q,qb);
  input s;
  input r;
  inout q;
  inout qb;
  wire w1,w2;
  supply0 gnd;
  supply1 vdd;
  pmos p1(w1,vdd,s);
  pmos p2(qb,w1,q);
  pmos p3(q,w2,qb);
  pmos p4(w2,vdd,r);
  nmos n1(qb,gnd,s);
  nmos n2(qb,gnd,q);
  nmos n3(q,gnd,qb);
  nmos n4(q,gnd,q);
endmodule

```

**OUTPUT:** The Truth Table of SRLATCH is verified.

**Program 12**

**2. STRUCTURAL GATE LEVEL MODELLING**

**2.1 OBTAIN FUNCTION  $F=[a+b+ac+bd]'$  using gate level modeling**

**Aim:-**

Design a structural gate level modeling for the AOI  $F=[a+b+ac+bd]'$

**Software Requirements:**

Synthesis tool:	Xilinx Project navigator – ISE 14.7
Simulation tool:	ModelSim Simulator

**Description:** Structural modeling describes a digital logic network in terms of the components that make up the system. Gate level modeling is based on using primitive logic gates and specifying how they are wired together.

This logic is constructed using primitive AND and NOR gates that takes the input a, b, c, d and produce an output of  $F=[a+b+ac+bd]'$ . W1 and w2 are the outputs of AND two gates which inturn are determined by the input values.

**LOGIC SYMBOL**

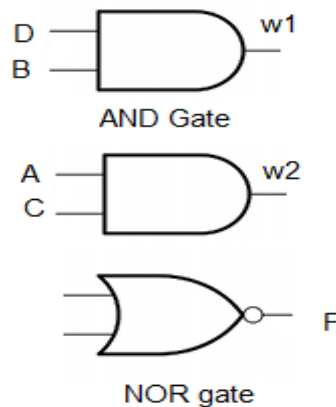

**TRUTH TABLE**

A	B	C	D	F
0	0	0	0	1
0	1	0	1	1
1	0	1	0	0
1	1	1	1	0

## LOGIC DIAGRAM

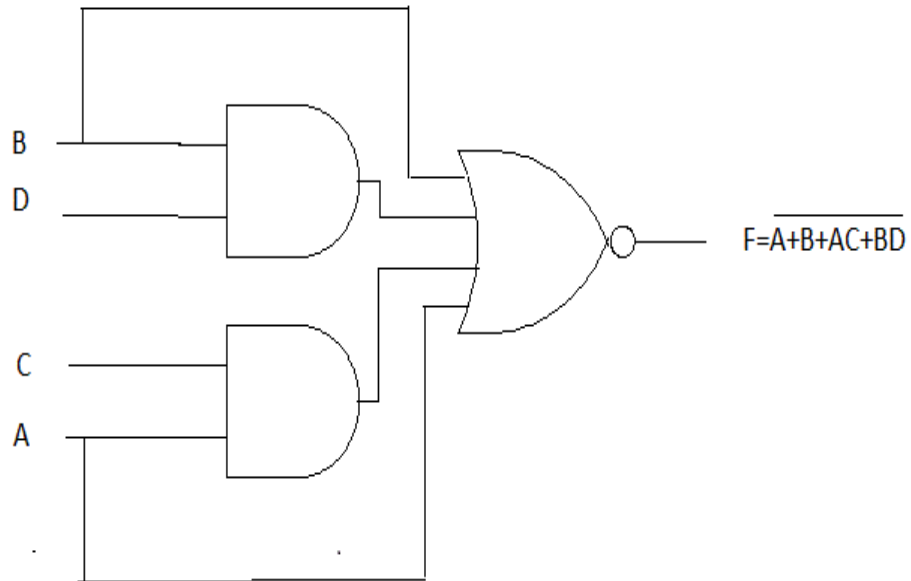

## VERILOG CODE

```
module func(a,b,c,d,f);  
  input a;  
  input b;  
  input c;  
  input d;  
  output f;  
  wire w1,w2;  
  and a1(w1,a,c);  
  and a2(w2,b,d);  
  nor n(f,w1,w2,a,b);  
endmodule
```

**OUTPUT:** The Truth Table of OAI is verified.

## 2.1 OBTAIN FUNCTION $F=[a+b+ac+bd]'$ using gate level modeling with delay

### VERILOG CODE

```
module func1(a,b,c,d,f);
  input a;
  input b;
  input c;
  input d;
  input f;
  wire w1,w2;
  and #(100,200) a1(w1,a,c);
  and #(100,200) a2(w2,b,d);
  nor #(100,200) n(f,w1,w2,a,b);
endmodule
```

### OUTPUT:

The Truth Table of OAI WITH DELAY is verified.

## Program 13

### 2.2 DESIGN HALF ADDER

**Aim:-**

Design a structural gate level modeling for the half adder

**Software Requirements:**

Synthesis tool:	Xilinx Project navigator – ISE 14.7
Simulation tool:	ModelSim Simulator

**Description:** Structural modeling describes a digital logic network in terms of the components that make up the system. Gate level modeling is based on using primitive logic gates and specifying how they are wired together.

A combinational circuit that performs the addition of two bits is called a half-adder. This circuit needs two binary inputs and produces two binary outputs. One of the input variables designates the augend and other designates the addend bits; the output variables designate sum and carry.

$$\text{sum} = a \oplus b.$$

$$\text{carry} = ab.$$

A combination of XOR gate and AND gate can be used to develop the circuit. Output of XOR gate is sum bit and that of AND gate is carry bit.

**LOGIC SYMBOL**

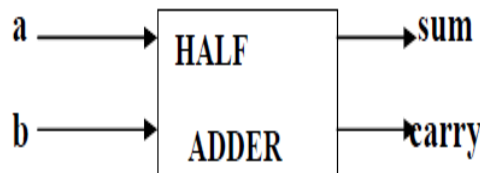



## TRUTH TABLE

a	b	sum	carry
0	0	0	0
0	1	1	0
1	0	1	0
1	1	0	1

## LOGIC DIAGRAM

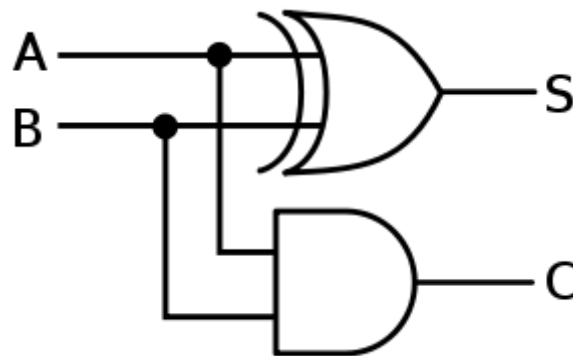

## VERILOG CODE

```
module half(a,b,s,c);  
  input a;  
  input b;  
  output s;  
  output c;  
  xor x(s,a,b);  
  and a1(c,a,b);  
endmodule
```

## OUTPUT:

The Truth Table of HALF ADDER is verified.

## 2.2 DESIGN HALF ADDER with delay

### VERILOG CODE

```
module half(a,b,s,c);  
  input a;  
  input b;  
  output s;  
  output c;  
  xor #(100,200) x(s,a,b);  
  and #(100,200) a1(c,a,b);  
endmodule
```

### OUTPUT:

The Truth Table of HALF ADDER WITH DELAY is verified.

## Program 14

### 2.3 DESIGN FULL ADDER

#### Aim:-

Design a structural gate level modeling for the full adder using two half adders and OR gate

#### Software Requirements:

Synthesis tool:	Xilinx Project navigator – ISE 14.7
Simulation tool:	ModelSim Simulator

**Description:** Structural modeling describes a digital logic network in terms of the components that make up the system. Gate level modeling is based on using primitive logic gates and specifying how they are wired together.

A combinational circuit that performs the addition of 3 bits is called a full adder. This circuit accepts 3 binary inputs and produces two binary outputs. The two outputs are denoted by sum and carry.

$$\text{sum} = a \oplus b \oplus c$$

$$\text{carry} = ab + bc + ca$$

A full can also be built from two half adders and an OR gate..

#### LOGIC SYMBOL

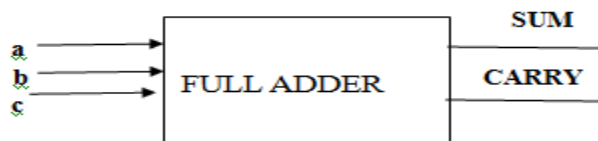

#### TRUTH TABLE

a	b	c	sum	carry
0	0	0	0	0
0	0	1	1	0
0	1	0	1	0
0	1	1	0	1
1	0	0	1	0
1	0	1	0	1
1	1	0	0	1
1	1	1	1	1

## LOGIC DIAGRAM

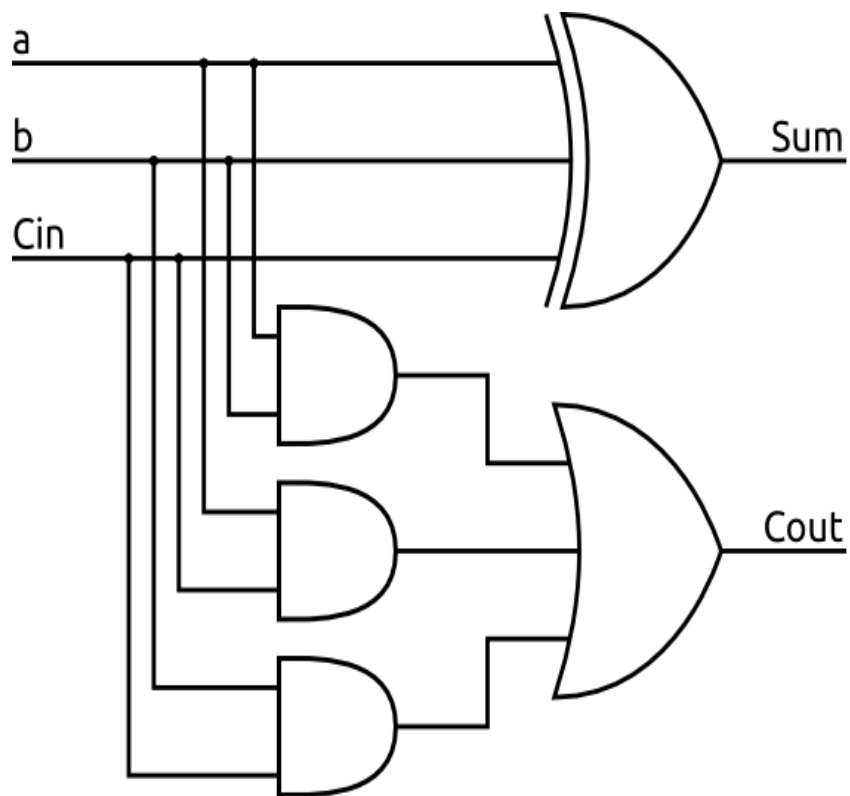

## VERILOG CODE

```
module fa(a,b,cin,s,c);
  input a;
  input b;
  input cin;
  output s;
  output c;
  wire w1,w2,w3;
  half h1(a,b,w1,w2);
  half h2(w1,cin,s,w3);
  or r(c,w3,w2);
endmodule
```

## OUTPUT:

The Truth Table of FULL ADDER is verified.

## 2.3 DESIGN FULL ADDER WITH DELAY

### VERILOG CODE

```
module fa(a,b,cin,s,c);
  input a;
  input b;
  input cin;
  output s;
  output c;
  wire w1,w2,w3;
  half #(100,200) h1(a,b,w1,w2);
  half #(100,200) h2(w1,cin,s,w3);
  or #(100,200) r(c,w3,w2);
endmodule
```

### OUTPUT:

The Truth Table of FULL ADDER WITH DELAY is verified.

## Program 15

### 2.4 IMPLEMENT 2:1 MUX USING TRI STATE BUFFERS

#### Aim:-

Design a structural gate level modeling for 2:1 MUX using tri state buffer.

#### Software Requirements:

Synthesis tool:	Xilinx Project navigator – ISE 14.7
Simulation tool:	ModelSim Simulator

**Description:** Structural modeling describes a digital logic network in terms of the components that make up the system. Gate level modeling is based on using primitive logic gates and specifying how they are wired together.

A tri-state buffer is similar to a buffer, but it adds an additional "enable" input that controls whether the primary input is passed to its output or not. If the "enable" inputs signal is **true**, the tri-state buffer behaves like a normal buffer. If the "enable" input signal is **false**, the tri-state buffer passes a *high impedance* (orhi-Z) signal, which effectively disconnects its output from the circuit.

#### LOGIC SYMBOL

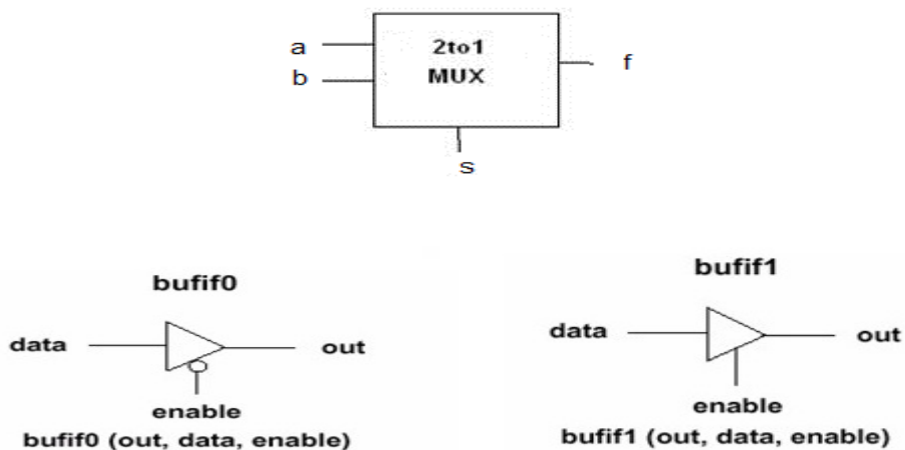

## TRUTH TABLE

<b>S</b>	<b>F</b>
<b>0</b>	<b>A</b>
<b>1</b>	<b>B</b>

## LOGIC DIAGRAM

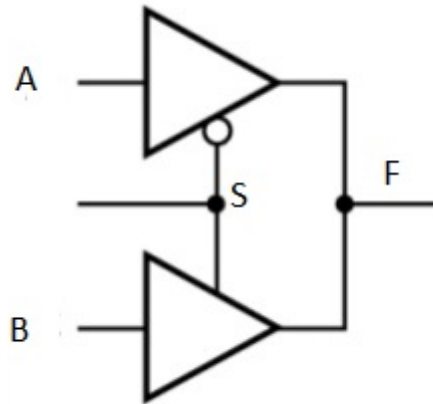

## VERILOG CODE

```
module trimux(a,b,en,f);
input a;
input b;
input en;
output f;
bufif0(f,a,en);
bufif1(f,b,en);
endmodule
```

## OUTPUT:

The Truth Table of 2:1 Mux Using Tri State Buffer Is verified.

## 2.4 IMPLEMENT 2:1 MUX USING TRI STATE BUFFERS WITH DELAY

### VERILOG CODE

```
module trimux(a,b,en,f);
  input a;
  input b;
  input en;
  output f;
  bufif0 #(100,200) (f,a,en);
  bufif1 #(100,200) (f,b,en);
endmodule
```

### OUTPUT:

The Truth Table of 2:1 Mux Using Tri State Buffer with delay is verified



## Program 16

### 2.5 IMPLEMENT 4:1 MUX USING 2:1 MULTIPLEXERS

#### Aim:-

Design a structural gate level modeling for 4:1 MUX using 2:1 MUX and tri state buffer.

#### Software Requirements:

Synthesis tool:	Xilinx Project navigator – ISE 14.7
Simulation tool:	ModelSim Simulator

**Description:** Structural modeling describes a digital logic network in terms of the components that make up the system. Gate level modeling is based on using primitive logic gates and specifying how they are wired together.

A tri-state buffer is similar to a buffer, but it adds an additional "enable" input that controls whether the primary input is passed to its output or not. If the "enable" input signal is **true**, the tri-state buffer behaves like a normal buffer. If the "enable" input signal is **false**, the tri-state buffer passes a *high impedance* (orhi-Z) signal, which effectively disconnects its output from the circuit.

A 4-to-1 Multiplexers has 4-data input lines ,two select lines and single output line. Three 2:1 Mux can be used to make a 4:1 mux. The first and second mux uses s1 as the select line and third uses s0 as the select line.

#### LOGIC SYMBOL

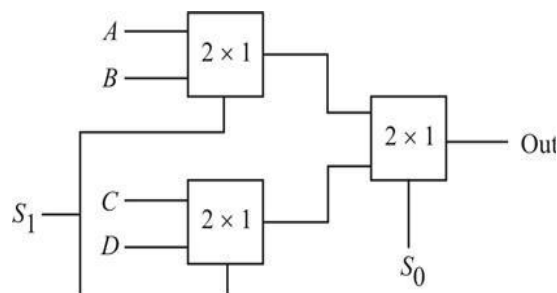

## TRUTH TABLE

$S_0$	$S_1$	Out
0	0	$A$
0	1	$B$
1	0	$C$
1	1	$D$

## LOGIC DIAGRAM

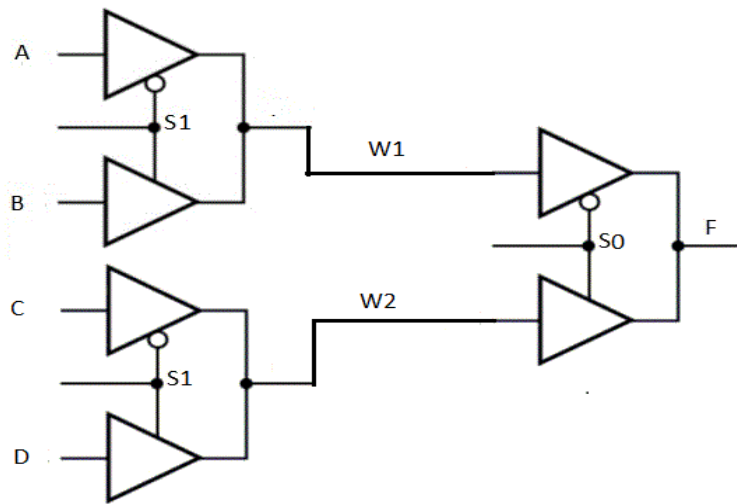

## VERILOG CODE

```
module trimux4(a,b,c,d,s0,s1,f);
  input a;
  input b;
  input c;
  input d;
  input s0;
  input s1;
  output f;
  wire w1,w2;
  trimux t1(a,b,s0,w1);
  trimux t2(c,d,s0,w2);
  trimux t3(w1,w2,s1,f);
endmodule
```

**OUTPUT:** The Truth Table of 4:1 MUX USING 2:1 MULTIPLEXER is verified

## 2.5 IMPLEMENT 4:1 MUX USING 2:1 MULTIPLEXERS WITH DELAY

### VERILOG CODE

```
module trimux4(a,b,c,d,s0,s1,f);
    input a;
    input b;
    input c;
    input d;
    input s0;
    input s1;
    output f;
    wire w1,w2;
    trimux #(100,200) t1(a,b,s0,w1);
    trimux #(100,200) t2(c,d,s0,w2);
    trimux #(100,200) t3(w1,w2,s1,f);
endmodule
```

**OUTPUT:** The Truth Table of 4:1 Mux Using 2:1 Multiplexer with delay is verified

## Program 17

### 2.6 SR LATCH

**Aim:-**

Design a structural gate level modeling for SR Latch.

**Software Requirements:**

Synthesis tool:	Xilinx Project navigator – ISE 14.7
Simulation tool:	ModelSim Simulator

**Description:** Structural modeling describes a digital logic network in terms of the components that make up the system. Gate level modeling is based on using primitive logic gates and specifying how they are wired together.

The logic diagram for SR latch can be obtained by using two NOR2 gates. The two NOR gates each have their output flow into the input of the other. There are two controllable inputs: reset (R) and set (S), which produce the two outputs: Q and Q("Q-not"). That's where the SR latch gets its name – it's a **set/reset** latch

**TRUTH TABLE**

S	R	$Q_{n+1}$	$\overline{Q}_{n+1}$	Operation
0	0	$Q_n$	$\overline{Q_n}$	hold
1	0	1	0	set
0	1	0	1	reset
1	1	0	0	not allowed

## LOGIC DIAGRAM

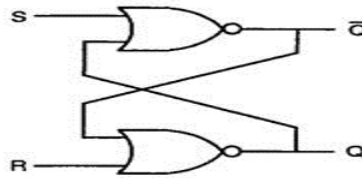

## VERILOG CODE

```
module srg(s,r,q,qb);
  input s;
  input r;
  inout q;
  inout qb;
  nor n1(qb,s,q);
  nor n2(q,r,qb);
endmodule
```

**OUTPUT:** The Truth table of SR latch is verified

## 2.6 IMPLEMENT SR LATCH WITH DELAY

### VERILOG CODE

```
module srg(s,r,q,qb);
  input s;
  input r;
  inout q;
  inout qb;
  nor #(100,200) n1(qb,s,q);
  nor #(100,200) n2(q,r,qb);
endmodule
```

**OUTPUT:** The Truth Table of SR latch with delay is verified

## Program 18

### 2.7 IMPLEMENT D – LATCH

#### Aim:-

Design a structural gate level modeling for D Latch.

#### Software Requirements:

Synthesis tool:	Xilinx Project navigator – ISE 14.7
Simulation tool:	ModelSim Simulator

**Description:** Structural modeling describes a digital logic network in terms of the components that make up the system. Gate level modeling is based on using primitive logic gates and specifying how they are wired together.

A latch (also called a **flip-flop**) is a fundamental component of **data storage**. A single latch can hold 1-bit of data, increase that number by *many* orders of magnitude and you can create kilo-, mega-, giga-, even tera-bytes of memory

#### TRUTH TABLE

D	Q	$\bar{Q}$
1	1	0
0	0	1

#### LOGIC DIAGRAM

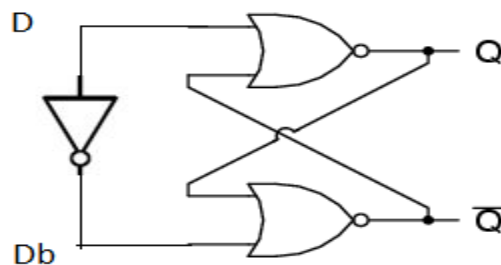

## VERILOG CODE

```
module dlatch(d,db,q,qb);  
    input d;  
    input db;  
    inout q;  
    inout qb;  
    not (db,d);  
    nor n1(qb,d,q);  
    nor n2(q,db,qb);  
endmodule
```

## OUTPUT:

The Truth Table of D-latch is verified



## 2.7 IMPLEMENT D – LATCH WITH DELAY

### VERILOG CODE

```
module dlatch(d,db,q,qb);
  input d;
  input db;
  inout q;
  inout qb;
  not #(100,200) (db,d);
  nor #(100,200) n1(qb,d,q);
  nor #(100,200) n2(q,db,qb);
endmodule
```

**OUTPUT:** The Truth Table of D-latch with delay is verified

## Program 19

### 3. HIERARCHICAL MODELING

#### 3.1 CONSTRUCT A 4 INPUT AND-GATE USING 2-INPUT NAND & NOR GATES

**Aim:-**

Design a 4 input and gate using 2-input nand & nor gates.

**Software Requirements:**

Synthesis tool:	Xilinx Project navigator – ISE 14.7
Simulation tool:	ModelSim Simulator

**Description:**

The concept of primitive, modules and instancing provides the basis for hierarchical design in Verilog. Complex systems can be described in Verilog HDL using mixed-design style modeling. This modeling style supports hierarchical description

Direct instantiation and connection of models from a separate calling model to form structural hierarchy in a design. A module may be declared anywhere in a design relative to where it is called.

The gate level and switch can be used separately or intermixed within a single module.

An AND gate can be created using already created switch level modules for NAND2 and NOR2. These gates can be instantiated to create the hierarchical design..

**TRUTH TABLE**

A	B	C	D	F
0	0	0	0	0
0	1	0	1	0
1	0	1	0	0
1	1	1	1	1

## LOGIC DIAGRAM

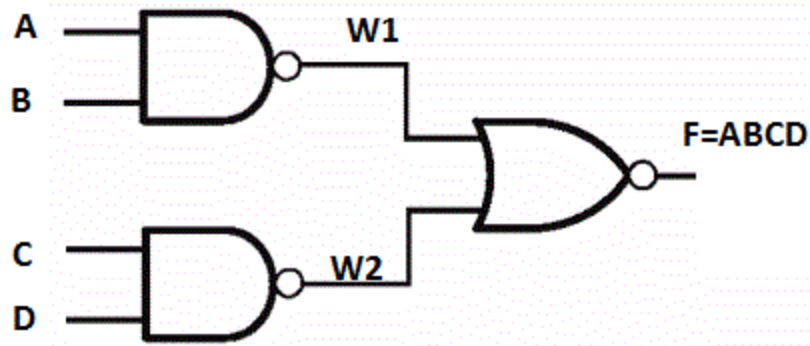

## VERILOG CODE

```
module and4(a,b,c,d,f);
  input a;
  input b;
  input c;
  input d;
  output f;
  wire w1,w2;
  nand1 n1(a,b,w1);// Instantiation of switch level NAND
  nand1 n2(c,d,w2);
  nor1 n3(w1,w2,f);
endmodule
```

**OUTPUT:** The Truth Table of 4 Input And-Gate Using 2-Input Nand & Nor Gate is verified.

## Program 20

### 3.2 CONSTRUCT AN 2:4 ACTIVE HIGH DECODER USING CMOS 2-INPUT NOR & NOT GATES

#### Aim:-

Design an 2:4 active high decoder using CMOS 2-input nor & not gates

#### Software Requirements:

Synthesis tool:	Xilinx Project navigator – ISE 14.7
Simulation tool:	ModelSim Simulator

#### Description:

The concept of primitive, modules and instancing provides the basis for hierarchical design in Verilog. Complex systems can be described in Verilog HDL using mixed-design style modeling. This modeling style supports hierarchical description

Direct instantiation and connection of models from a separate calling model to form structural hierarchy in a design. A module may be declared anywhere in a design relative to where it is called.

The gate level and switch can be used separately or intermixed within a single module.

A decoder is a circuit which has n inputs and  $2^n$  outputs, and outputs 1 on the wire corresponding to the binary number represented by the inputs

#### LOGIC SYMBOL

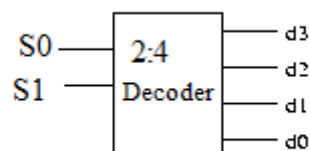

## TRUTH TABLE

S1	S0	D0	D1	D2	D3
0	0	1	0	0	0
0	1	0	1	0	0
1	0	0	0	1	0
1	1	0	0	0	1

## LOGIC DIAGRAM

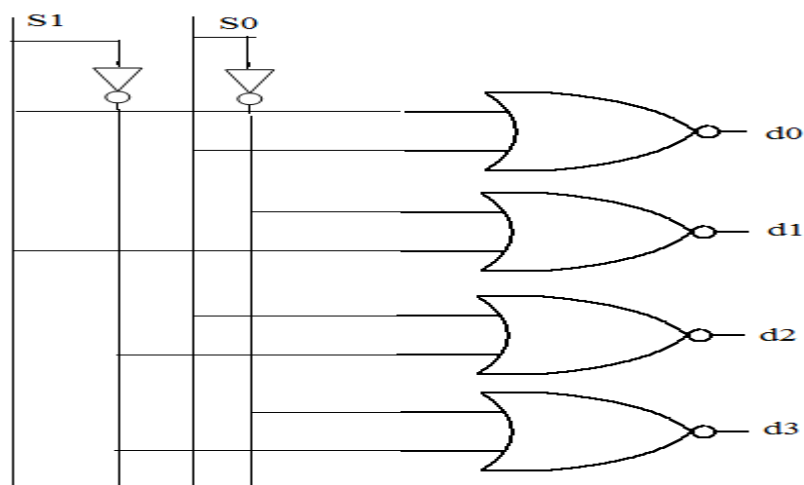

## VERILOG CODE

```
module decode24(s0,s1,d0,d1,d2,d3);
  input s0;
  input s1;
  output d0;
  output d1;
  output d2;
  output d3;
  wire s0b,s1b;
  not1 n1(s0,s0b);
  not1 n2(s1,s1b);
  nor1 n3(s1,s0,d0);
  nor1 n4(s1b,s0,d1);
  nor1 n5(s1,s0b,d2);
  nor1 n6(s1b,s0b,d3);
endmodule
```

**OUTPUT:** The Truth Table of 2:4 active high decoder using CMOS 2-input nor & not gates is verified.

## Program 21

### 3.2 CONSTRUCT SR LATCH USING HIERARCHICAL MODELING

#### Aim:-

Design a SR Latch

#### Software Requirements:

Synthesis tool:	Xilinx Project navigator – ISE 14.7
Simulation tool:	ModelSim Simulator

#### Description:

The concept of primitive, modules and instancing provides the basis for hierarchical design in Verilog. Complex systems can be described in Verilog HDL using mixed-design style modeling. This modeling style supports hierarchical description

Direct instantiation and connection of models from a separate calling model to form structural hierarchy in a design. A module may be declared anywhere in a design relative to where it is called.

The gate level and switch can be used separately or intermixed within a single module.

A latch (also called a **flip-flop**) is a fundamental component of **data storage**. A single latch can hold 1-bit of data, increase that number by *many* orders of magnitude and you can create kilo-, mega-, giga-, even tera-bytes of memory

The logic diagram for SR latch can be obtained by using two NOR2 gates. The two NOR gates each have their output flow into the input of the other. There are two controllable inputs: reset (R) and set (S), which produce the two outputs: Q and Q("Q-not"). That's where the SR latch gets its name – it's a **set/reset** latch.

## LOGIC SYMBOL

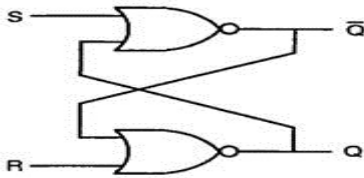

## TRUTH TABLE

S	R	$Q_{n+1}$	$\overline{Q}_{n+1}$	Operation
0	0	$Q_n$	$\overline{Q}_n$	hold
1	0	1	0	set
0	1	0	1	reset
1	1	0	0	not allowed

## VERILOG CODE

```
module srh(s,r,q,qb);
  input s;
  input r;
  inout q;
  inout qb;
  nor1 n1(s,q,qb);
  nor1 n2(r,qb,q);
endmodule.
```

**OUTPUT:** The Truth Table of SR Latch Using Hierarchical Modeling is verified

## Program 22

### 3.2 CONSTRUCT D LATCH USING HIERARCHICAL MODELING

#### Aim:-

Design a D Latch

#### Software Requirements:

Synthesis tool:	Xilinx Project navigator – ISE 14.7
Simulation tool:	ModelSim Simulator

#### Description:

The concept of primitive, modules and instancing provides the basis for hierarchical design in Verilog. Complex systems can be described in Verilog HDL using mixed-design style modeling. This modeling style supports hierarchical description

Direct instantiation and connection of models from a separate calling model to form structural hierarchy in a design. A module may be declared anywhere in a design relative to where it is called.

The gate level and switch can be used separately or intermixed within a single module.

A latch (also called a **flip-flop**) is a fundamental component of **data storage**. A single latch can hold 1-bit of data, increase that number by *many* orders of magnitude and you can create kilo-, mega-, giga-, even tera-bytes of memory

In the verilog code not gate is called using switch level and nor gates are called using gate level.

#### TRUTH TABLE

D	Q	$\bar{Q}$
1	1	0
0	0	1



## LOGIC DIAGRAM

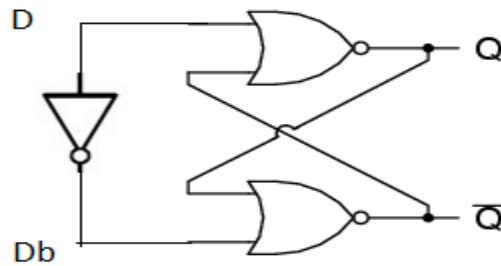

## VERILOG CODE

```
module dh(d,db,q,qb);  
  input d;  
  input db;  
  inout q;  
  inout qb;  
  not1 n(d,db);  
  nor1 n1(d,q,qb);  
  nor1 n2(db,qb,q);  
endmodule
```

**OUTPUT:** The Truth Table of D Latch using hierarchical modeling is verified.

## 3. REGISTER TRANSFER LEVEL (RTL) MODELING

### REGISTER TRANSFER LEVEL (RTL) MODELING

- At RTL digital design abstraction, registers are the basic components (primitives).
- Data paths are defined by their registers and the operations performed on the data stored in the registers.
- An elementary operation performed on data stored in a register is called *micro operation*
- Copying the contents of one register into another
- Adding the contents of two registers
- Storing result into a register
- Shift and count
- Incrementing the contents of a register.

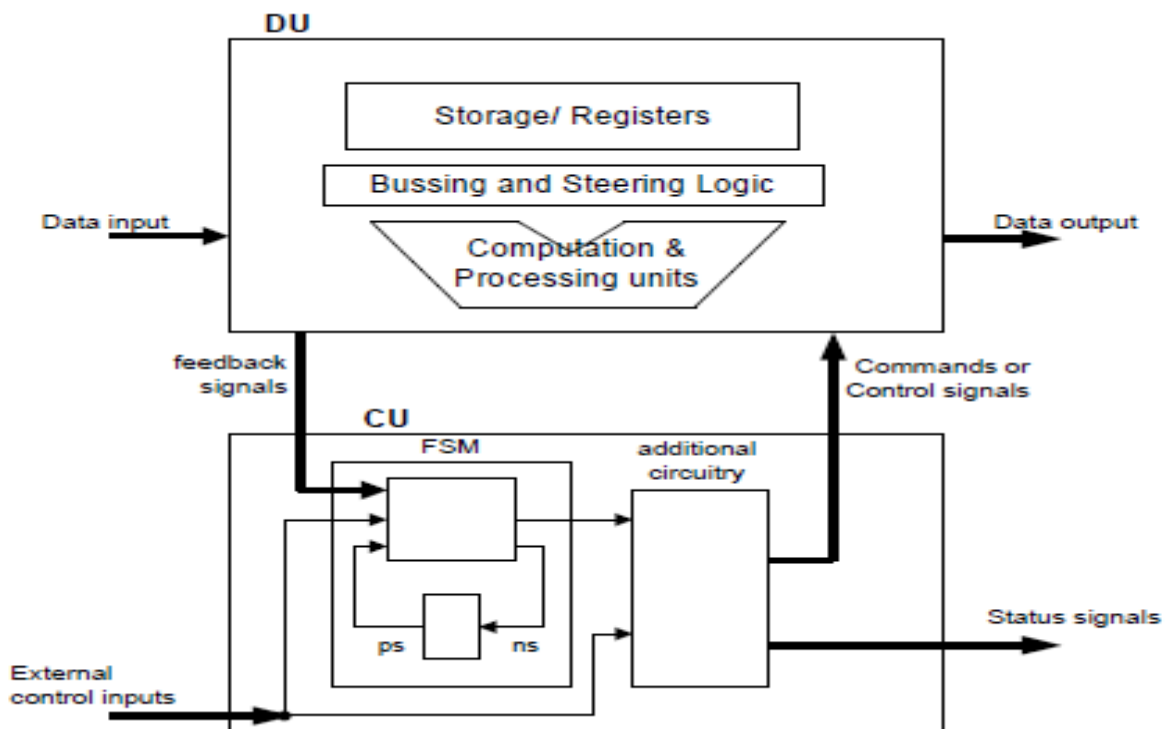

The movement and processing of the data stored in registers are termed *register transfer operations* or *RTL operations*

- An RTL operation can be considered as a combination of the elementary micro operations.

- It is a fact that almost all synchronous sequential digital systems can be viewed as a set of registers and operations that transfer data.
- These RTL operations of a digital system are completely specified by three basic elements:
  - The register set,
  - The operations that are performed on data in registers
  - The sequence of the operations.

In other words, the digital system can be described and modeled by a **RTL Control Sequence** (RTLCS for short) or **RTL code**/program.

- This RTL code uses an associated notational system, called *Register Transfer Notation (RTN)*.
  - Operations in RTN are almost always of the form:  
$$\text{regA} \leftarrow f(\text{reg1}, \text{reg2}, \dots, \text{regn})$$

## BEHAVIORAL MODELING

Behavioral modeling is the highest level of abstraction in the Verilog HDL. The other modeling techniques are relatively detailed. They require some knowledge of how hardware or hardware signals work. The abstraction in this modeling is as simple as writing the logic in C language. This is a very powerful abstraction technique. All that the designer needs is the algorithm of the design, which is the basic information for any design.

Most of the behavioral modeling is done using two important constructs: initial and always. All the other behavioral statements appear only inside these two structured procedure constructs.

### initial Construct

Statements which come under the *initial* construct constitute the initial block. The initial block is executed only once in the simulation, at time 0. If there is more than one initial block, then all the initial blocks are executed concurrently. The initial construct is used as follows:

```
Initial                               initial
begin                                  or
reset = 1'b0;                          clk = 1'b1;
clk = 1'b1;
end
```

In the first initial block there is more than one statement hence they are written between begin and end. If there is only one statement then there is no need to put begin and end.

### always Construct

Statements which come under the *always* construct constitute the always block. The always

block starts at time 0, and keeps on executing all the simulation time. It works like a infinite loop. It is generally used to model a functionality that is continuously repeated.

```
Always                                initial  
clk = 1'b0;                           #5 clk = ~clk;
```

The above code generates a clock signal clk, with a time period of 10 units. The initial blocks initiates the clk value to 0 at time 0. Then after every 5 units of time it toggled, hence we get a time period of 10 units.

## Program 23

### 4.1 Write Verilog code to implement 4:1 multiplexer using RTL and Behavioral modeling.

**Aim :-** Design 4:1 multiplexer using RTL and Behavioral modeling.

#### Software Requirements:

Synthesis tool:	Xilinx Project navigator – ISE 14.7
Simulation tool:	ModelSim Simulator

**Description:** 4:1 mux has four inputs lines I0 to I3 and one output F. It consists of two select lines s0 and s1. It is implemented using three 2:1 mux.

RTL (Register transfer level) is step by step process which uses low level keywords, it uses assign as a keyword, Behavioral modeling is architectural modeling .It is module based or object based.

#### LOGIC SYMBOL

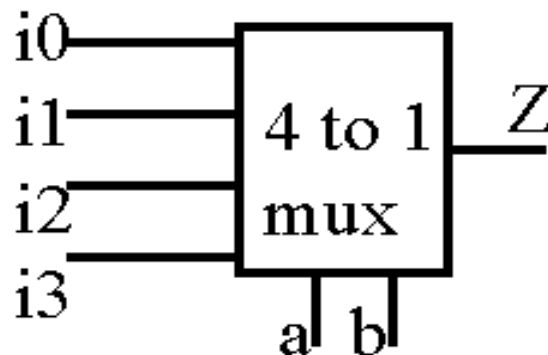

## LOGICAL DIAGRAM

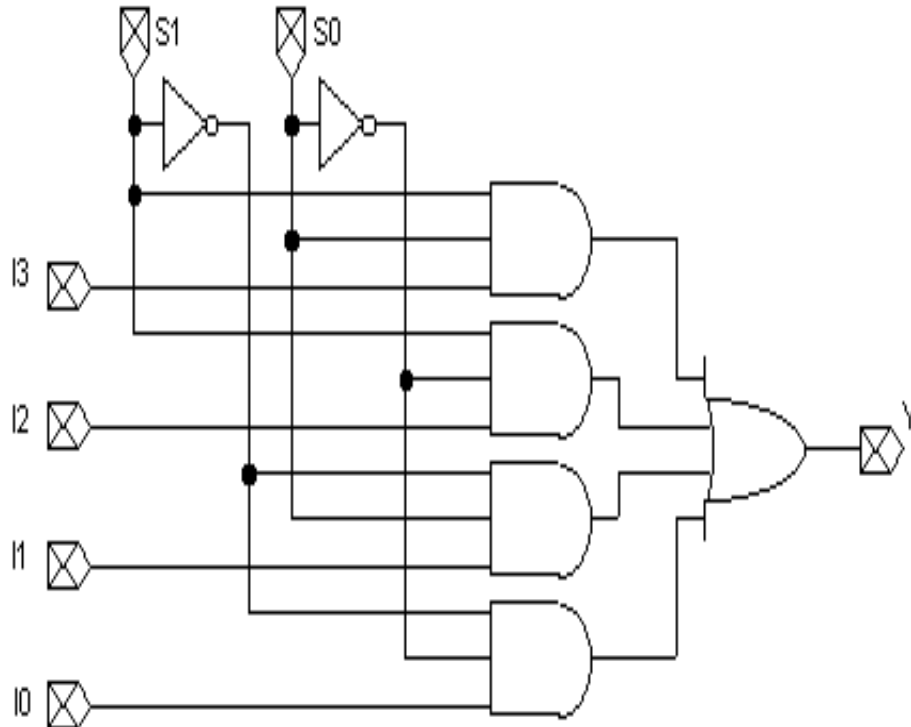

## TRUTH TABLE

S1	S0	Y
0	0	I0
0	1	I1
1	0	I2
1	1	I3

S1 \ S0	0	1
0	I0	I1
1	I2	I3

## RTL CODE

```
module rtl41(s,i,f);
    input [1:0]s;
    input [3:0]i;
    output f;
    assign f=(~s[0]& ~s[1]& i[0]|~s[0]& s[1]& i[1]|
    s[0]& ~s[1]& i[2]|s[0]& s[1]& i[3]);
endmodule
```

## BEHAVIOURAL CODE

```
module b41(s,i,f);
    input [0:0] s;
    input [3:0] i;
    output f;
    reg f;
    always @(s)
    case(s)
    0:f=i[0];
    1:f=i[1];
    2:f=i[2];
    3:f=i[3];
    endcase
endmodule
```

**OUT PUT:** The Truth Table of 4:1 mux is verified

## Program 24

### 4.2 Write Verilog code to implement 2:4 Active High Decoder using RTL and Behavioral modeling

**Aim** Design 2:4 Active High Decoder using RTL and Behavioral modeling.

#### Software Requirements:

Synthesis tool:	Xilinx Project navigator – ISE 14.7
Simulation tool:	ModelSim Simulator

**Description:** Decoder is quite similar to demux 2:4 decoder take 2 inputs (s0 & s1) and 4 outputs (d0,d1,d2,d3)

RTL (Register transfer level) is step by step process which uses low level keywords, it uses assign as a keyword , Behavioral modeling is a architectural modeling .It is module based or object based.

#### LOGIC SYMBOL

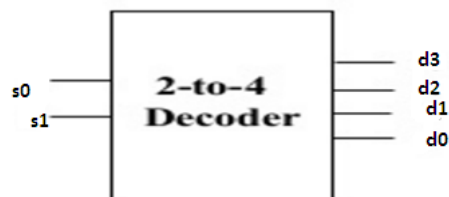



**LOGIC DIAGRAM**

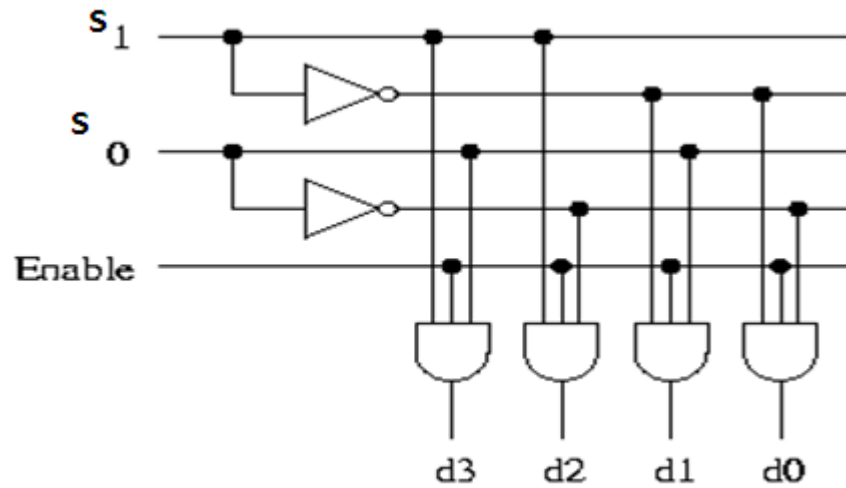

**TRUTH TABLE**

I/P	Select		O/P			
	s0	s1	D0	D1	D2	D3
1	0	0	1	0	0	0
1	0	1	0	1	0	0
1	1	0	0	0	1	0
1	1	1	0	0	0	1

## RTL CODE:

```
module rtl24(s,d0,d1,d2,d3);
    input [1:0] s;
    output d0;
    output d1;
    output d2;
    output d3;
    assign d0=(~s[0]&~s[1]);
    assign d1=(s[0]&~s[1]);
    assign d2=(~s[0]&s[1]);
    assign d3=(s[0]&s[1]);
endmodule
```

## Behavioral code

```
module b24(s,d,f);
    input [1:0]s;
    output [3:0]d;
    output f;
    reg f;
    always @(s)
    case(s)
    8:f=d[0];
    4:f=d[1];
    2:f=d[2];
    1:f=d[3];
    endcase
endmodule
```

**OUT PUT:** The Truth Table of 2:4 active high decoder is verified

## Program 25

### 4.3 Write Verilog code to implement 4-BIT Priority encoder using RTL and Behavioral modeling

**AIM:** Design a 4-BIT Priority encoder using RTL and Behavioral modeling

#### SOFTWARE REQUIREMENTS:

Synthesis tool:	Xilinx Project navigator – ISE 14.7
Simulation tool:	ModelSim Simulator

**DESCRIPTION:** A 4-bit priority encoder basically converts the 4 bit input into a binary representation. A common user of priority encoder is for interrupt controller to select the most critical of the multiple interrupt requests

RTL (Register transfer level) is step by step process which uses low level keywords, it uses assign as a keyword, Behavioral modeling is a architectural modeling .It is module based or object based.

#### LOGIC SYMBOL

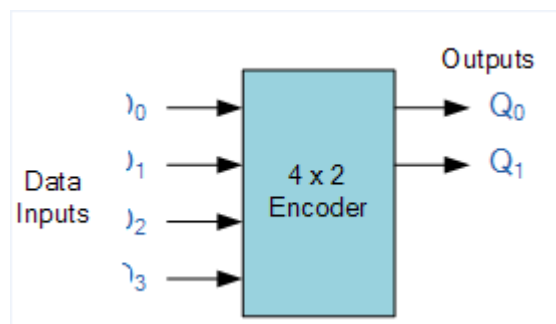

## LOGIC DIAGRAM

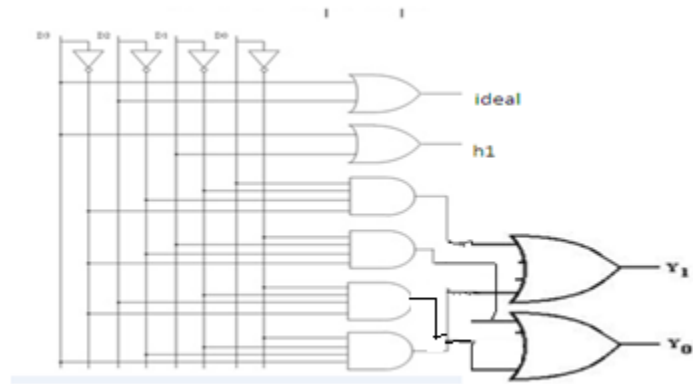

## TRUTH TABLE

$i_3$	$i_2$	$i_1$	$i_0$	ideal	$y_0$	$y_1$
0	0	0	0	1	0	0
0	0	0	1	0	0	0
0	0	1	X	0	0	1
0	1	X	X	0	1	0
1	x	X	X	0	1	1

## RTL CODE

```
module priorityb(i0,i1,i2,i3,y0,y1,idle);
    input [3:0] i;
    output [1:0] y;
    output idle;
    output y0;
    output y1;
    wire h1,h2,h3,h4;
    assign h1=~(i3)&~(i2)&(i1)&(i0);
    assign h2=~(i3)&~(i2)&(i1);
    assign h3=~(i3)&(i2);
    assign h4=(i3);
    assign idle=~(i3)&~(i2)&~(i1)&~(i0);
    assign y1=h2|h4;
    assign y0=h3|h4;
endmodule
```

## BEHAVIORAL MODELING

```
module priorityb(i,y,idle);
    input [3:0] i;
    output [1:0] y;
    output idle;
    reg[1:0]y;
    reg idle;
    always @ (i)
    if(i==0)
    begin
    idle=1;
    y[0]=0;
    y[1]=0;
    end
    else if(i[3]==1)
    begin
    idle=0;
    y[0]=1;
    y[1]=1;
    end
    else if(i[2]==1)
    begin
    idle=0;
    y[0]=1;
    y[1]=0;
    end
    else if(i[1]==1)
    begin
    idle=0;
    y[0]=0;
```

```
y[1]=1;
end
else if(i[0]==1)
begin
idle=0;
y[0]=0;
y[1]=0;
end
endmodule
```

**OUT PUT:** The Truth Table of 4 bit priority encoder is verified

## Program 26

### 4.4 Write Verilog code to implement JK Flip Flop for negative edge triggered using RTL and Behavioral modeling

**AIM:** Design JK FILP FLOP for –ve edge triggered using RTL and Behavioral modeling

#### SOFTWARE REQUIREMENTS:

Synthesis tool:	Xilinx Project navigator – ISE 14.7
Simulation tool:	ModelSim Simulator

**DESCRIPTION:** JK filpflop is the most versatile of the basic flip-flops. It has the input following characters of the clocked D-flip-flop, but has two inputs labeled J and K . If J and K are different then the output Q takes the value of J at the next clock edge.

RTL (Register transfer level) is step by step process which uses low level keywords, it uses assign as a keyword , Behavioral modeling is a architectural modeling .It is module based or object based.

#### LOGIC SYMBOL

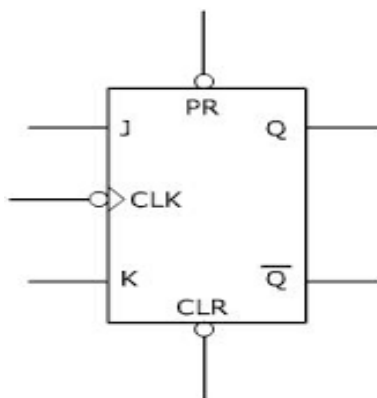

## LOGIC DIAGRAM

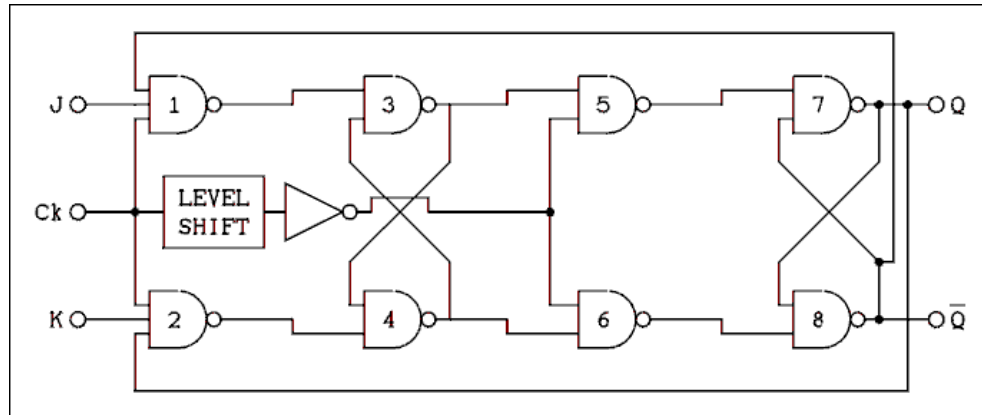

## TRUTH TABLE

CLK	PRESET	clear	J	K	q	Qb
1	1	0	X	X	0	1
1	1	1	0	0	qp	qbp
1	1	1	0	1	0	1
1	1	1	1	0	1	0
1	1	1	1	1	1/0	1/0

## RTL CODE

```

module jk(j,k,pr,clr,clk,q,qb);
    input j;
    input k;
    input pr;
    input clr;
    input clk;
    output q;
    output qb;
    wire w1,w2,w3,w4,w5,w6;
    assign w1=~(j&q&clk);
    assign w2=~(k&q&clk);
    assign w3=~(w1&pr&w4);
    assign w4=~(w2&clr&w3);
    assign w5=~(w3&(~clk));
    assign w6=~(w4&(~clk));
    assign q=~(w5&qb);

```



```
assign qb=~(w6&q);  
endmodule
```

**OUT PUT:** The Truth Table of negative edge triggered JK flipflop is verified

## Program 27

### 4.5 Write Verilog code to implement D FILP FLOP using RTL

**AIM:** Design D FILP FLOP using RTL modeling

#### SOFTWARE REQUIREMENTS:

Synthesis tool:	Xilinx Project navigator – ISE 14.7
Simulation tool:	ModelSim Simulator

**DESCRIPTION:** D flip-flop is also known as data or delay flip-flop. This flip-flop captures the value of the D-input at the definite portion of the clock cycle. That captured value of the D becomes the output Q. IT can be viewed as a memory cell, a zero order hold or delay line. D flip-flop forms the basis for the shift register which are an essential part of many electronic devices.

RTL (Register transfer level) is step by step process which uses low level keywords, it uses assign as a keyword, Behavioral modeling is a architectural modeling .It is module based or object based.

#### LOGIC SYMBOL

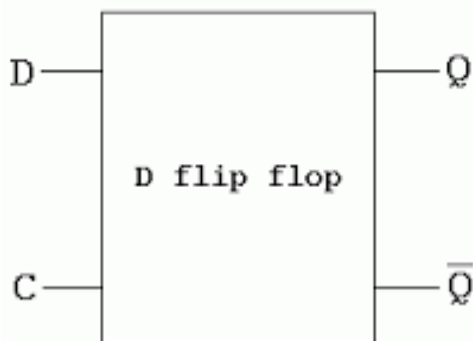

## LOGIC DIAGRAM

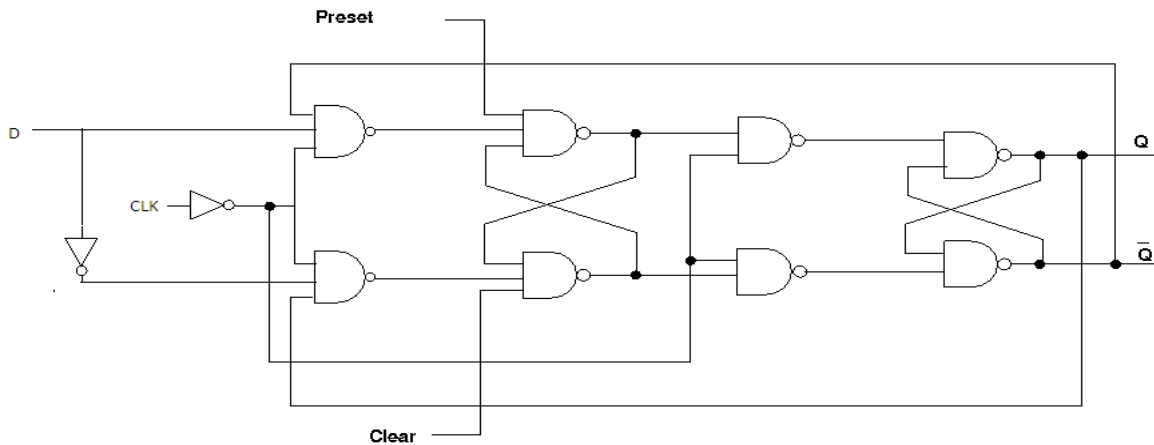

## TRUTH TABLE

CLK	PRESET	clear
1	1	0
1	1	1

d	db	q	qb
0	1	0	1
1	0	1	0

## RTL CODE

```

module dp(d,db,pr,clr,clk,q,qb);
    input d;
    input db;
    input pr;
    input clr;
    input clk;
    output q;
    output qb;
    wire w1,w2,w3,w4,w5,w6;
    assign db=~(d);
    assign w1=~(d&qb&(~clk));
    assign w2=~(db&q&(~clk));
    assign w3=~(w1&pr&w4);
    assign w4=~(w2&clr&w3);
    assign w5=~(w3&clk);
    assign w6=~(w4& clk);
    assign q=~(w5&qb);
    assign qb=~(w6&q);
endmodule
    
```

**OUT PUT:** The Truth Table of D Flip Flop is verified

## Program 28

### 4.6 Write Verilog code to implement T FILP FLOP using RTL modeling

**AIM:** Design T FILP FLOP using RTL modeling

#### SOFTWARE REQUIREMENTS:

Synthesis tool:	Xilinx Project navigator – ISE
Simulation tool:	ModelSim Simulator

**DESCRIPTION:** T – Flip flop is similar to D-ff to some extent. The only difference is that D-flip flop is uses a delay line while T-flipflop uses a toggle. If the T –input is high the flipflop changes the state (toggles). Whenever the clock input is high if the T input is low the ff holds the previous value.

RTL (Register transfer level) is step by step process which uses low level keywords, it uses assign as a keyword, Behavioral modeling is a architectural modeling .It is module based or object based.

#### LOGIC SYMBOL

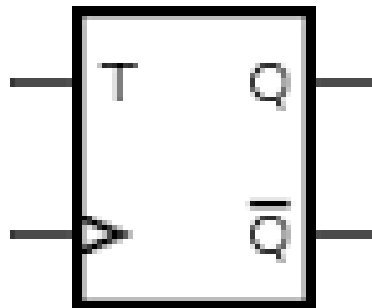

## LOGIC DIAGRAM

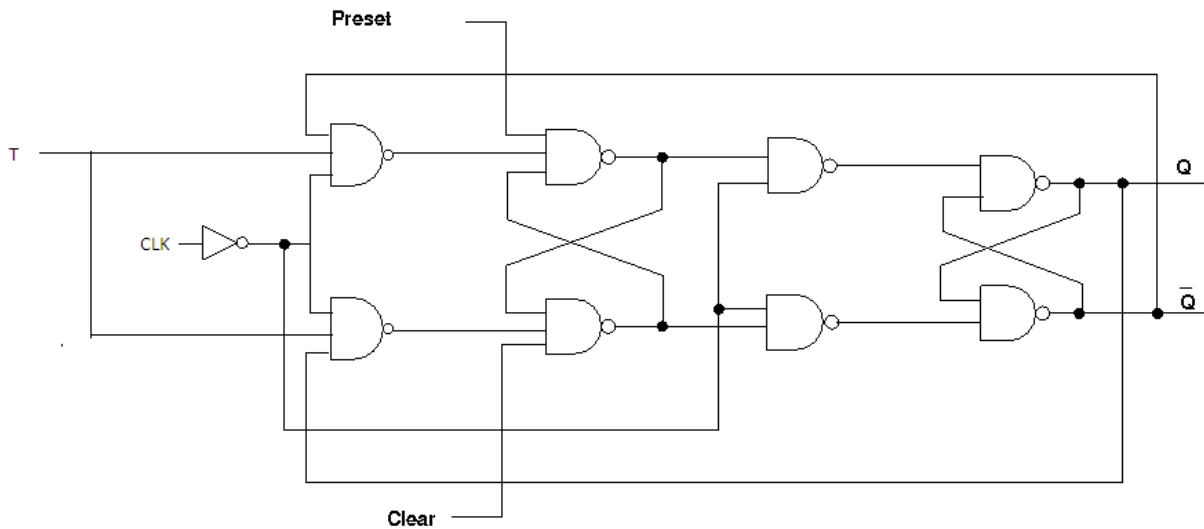

## TRUTH TABLE

pr	clr	clk	T	q	qb
1	0	1	0	0	1
1	1	1	1	1	1

## RTL CODE

```

module tff(t,pr,clr,clk,q,qb);
    input t;
    input pr;
    input clr;
    input clk;
    output q;
    output qb;
    wire w1,w2,w3,w4,w5,w6;
    assign w1=~(t&qb&(~clk));
    assign w2=~(t&q&(~clk));
    assign w3=~(w1&pr&w4);
    assign w4=~(w2&clr&w3);
    assign w5=~(w3&clk);
    assign w6=~(w4& clk);
    assign q=~(w5&qb);
    assign qb=~(w6&q);
endmodule
    
```

**OUT PUT:** The Truth Table of T Flip Flop is verified

## Program 29

### 4.7 Write Verilog code to implement 4 BIT LOADABLE SISO/PIPO shift register using RTL modeling

**AIM:** Design 4 BIT LOADABLE SISO/PIPO shift register using RTL modeling

#### SOFTWARE REQUIREMENTS:

Synthesis tool:	Xilinx Project navigator – ISE 14.7
Simulation tool:	ModelSim Simulator

**DESCRIPTION:** Shift register can have both parallel and serial inputs and outputs. These are often configured as “serial in” & “serial out” (SISO) OR “parallel in , serial out”(PIPO).

A basic four-bit shift register can be constructed using four D flip-flops. Serial-in, serial-out shift registers delay data by one clock time for each stage. They will store a bit of data for each register. The operation of the circuit is as follows. If load =0 the register is first cleared, forcing all four outputs to zero. The input data is then applied sequentially to the D input of the first flip-flop on the left. During each clock pulse, one bit is transmitted from left to right

If load =1 the circuit behaves as PIPO. For parallel in - parallel out shift registers, all data bits appear on the parallel outputs immediately following the simultaneous entry of the data bits.

RTL (Register transfer level) is step by step process which uses low level keywords, it uses assign as a keyword, Behavioral modeling is a architectural modeling .It is module based or object based.

## LOGIC DIAGRAM

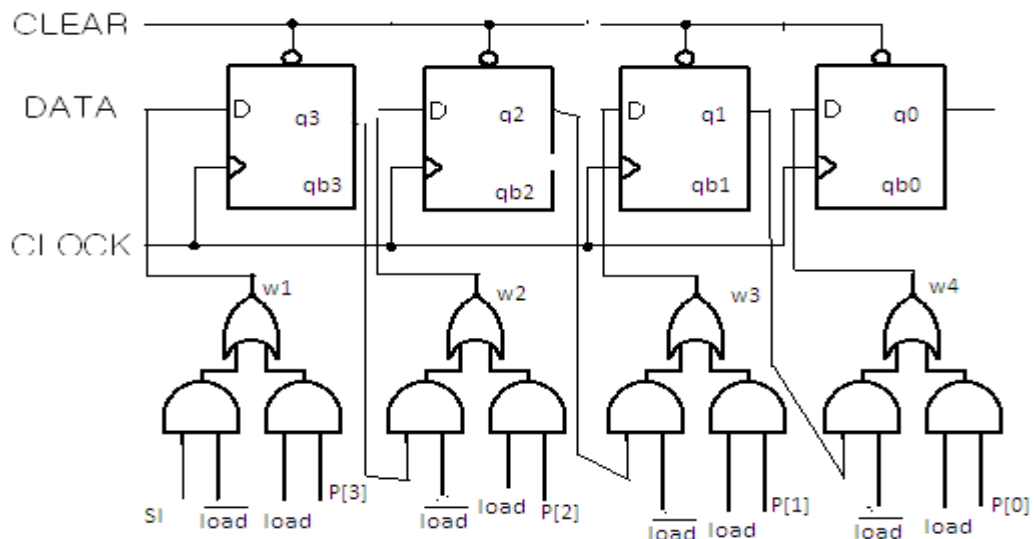

## TRUTH TABLE

CLK	LR	PR	SI	q3	q2	q1	q0
1	0	1	1	0	0	0	0
1	1	1	1	0	0	0	0
1	1	1	0	1	0	0	0
1	1	1	1	0	1	0	0
1	1	1	1	1	0	1	0
1	1	1	0	1	1	0	1
1	1	1			1	1	0
1	1	1				1	1
1	1	1					1

## RTL CODE

```
module siso(si,pr,clr,clk,p,load,q);
    input si;
    input pr;
    input clr;
    input clk;
    input [3:0] p;
    input load;
    output [3:0] q;
    wire w1,w2,w3,w4;
    assign w1=((si&(~load))||(load&p[3]));
    assign w2=((q[3]&(~load))||(load & p[2]));
    assign w3=((q[2] & (~load))||(load & p[1]));
    assign w4=((q[1] & (~load))||(load & p[0]));
    dp d1(w1,pr,clr,clk,q[3],qb[3]);
    dp d2(w2,pr,clr,clk,q[2],qb[2]);
    dp d3(w3,pr,clr,clk,q[1],qb[1]);
    dp d4(w4,pr,clr,clk,q[0],qb[0]);
endmodule
```

**NOTE: For PIPO output is same as input.**

**OUTPUT:** The truth table of SISO/PIPO is verified



## Program 30

### 4.9 Implement Ripple Carry Adder using RTL and Behavioral Modeling

Aim : Write Verilog code to implement Ripple Carry Adder using RTL and Behavioral modeling

#### Software Requirements:

Synthesis tool:	Xilinx Project navigator – ISE 14.7
Simulation tool:	ModelSim Simulator

**Description:** Ripple carry adder A ripple carry adder is a digital circuit that produces the arithmetic sum of two binary numbers. It can be constructed with full adders connected in cascaded (see section 2.1), with the carry output from each full adder connected to the carry input of the next full adder in the chain. Below figure shows the inter connection of four full adder (FA) circuits to provide a 4-bit ripple carry adder.

From that the input is from the right side because the first cell traditionally represents the least significant bit (LSB). Bits  $a_0$  and  $b_0$  in the figure represent the least significant bits of the numbers to be added. The sum output is represented by the bits  $s_0$ - $s_3$

#### **One-bit full adder**

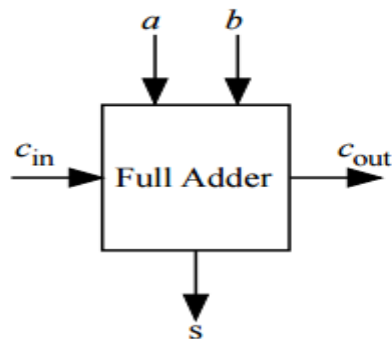

4-bit full adder.

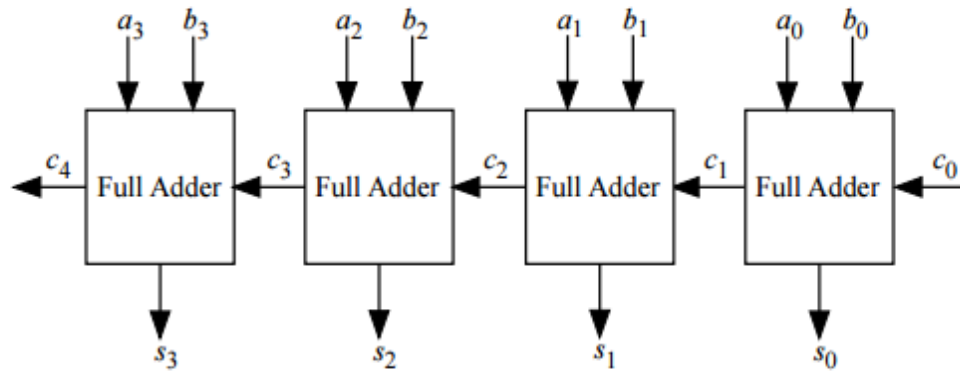

4-Bit Carry ripple adder : Assume you want to add two operands A & B where

A= A3 A2 A1 A0

B= B3 B2 B1 B0

A = 1 0 1 1

B = 1 1 0 1

-----

A+B = 1 1 0 0 0 = Cout s3 s2 s1 s0

## RTL CODE:

```
Module rtl rc(c,c4,a,b,c0)
input[3:0]a,b;
input c0;
output[3:0]s,c4;
assign{c4,s}=a+b+c0;
endmodule
```

## Behavioural modelling

```
module rip(a,b,c0,s,c4)
input[3:0]a,b;
input c0;
output[3:0]s,c4;
regc4;
```

```
regs;  
always @ (a:b:c0);  
begin  
(s,c4)= a+b+c0;  
end  
endmodule
```

## Program 31

### 4.8 Write Verilog code to implement 4 bit carry look ahead (CLA) using RTL and Behavioral modeling

**AIM:** Design a 4bit carry look ahead (CLA) using RTL and Behavioral modeling

#### SOFTWARE REQUIREMENTS:

Synthesis tool:	Xilinx Project navigator – ISE 14.7
Simulation tool:	ModelSim Simulator

**DESCRIPTION:** The carry look ahead adder (CLA) solves the carry delay problem by calculating the carry signal in advance based on the inputs signals Or It is used to decrease calculation time in adder units.

$$C_{i+1} = G_i + P_i \cdot C_i$$

$$S_i = P_i \oplus C_i$$

$$G_i = a_i b_i$$

$$P_i = a_i \oplus b_i$$

$$C_{i+1} = a_i b_i + C_i (a_i \oplus b_i)$$

Where  $G_i$  --- carry generate then

$P_i$  ---- carry propagate

RTL (Register transfer level) is step by step process which uses low level keywords, it uses assign as a keyword, Behavioral modeling is a architectural modeling .It is module based or object based.

## LOGIC SYMBOL

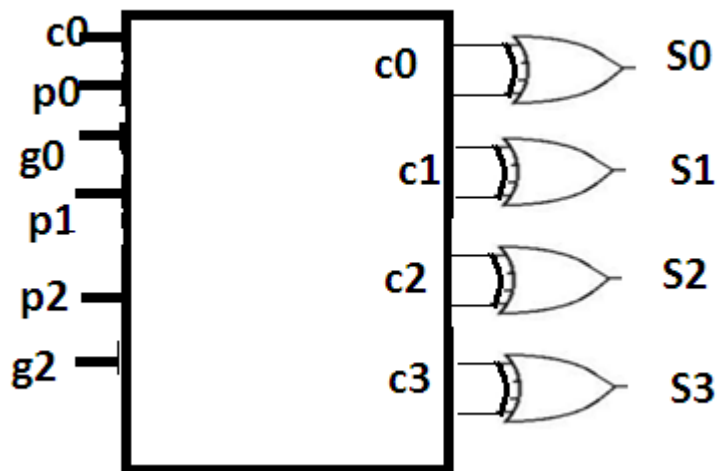

## LOGIC DIAGRAM

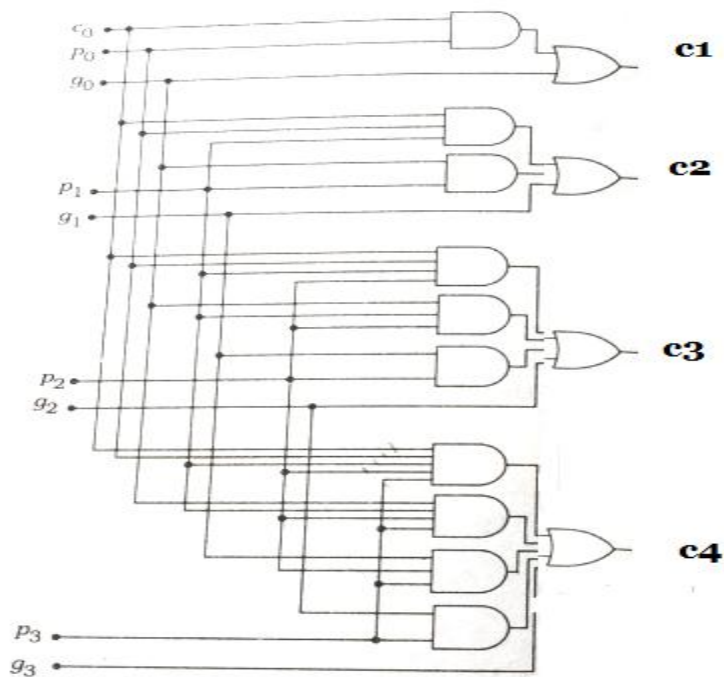

## TRUTH TABLE

a	b	c0	s	c4
1	1	0	0	1
0	0	0	0	0
1	0	0	1	0
0	1	0	0	1

## RTL CODE

```
module CLA_4b(sum ,c4, a,b,c0);
    input [3:0] a,b;
    input c0;
    output [3:0] sum;
output_4;
    wire p0, p1,p2,p3,g0,g1,g2,g3,c1,c2,c3,c4;

assign

p0=a[0]^b[0];
p1=a[1]^b[1];
p2=a[2]^b[02];
p3=a[3]^b[3];
g0=a[0]&b[0];
g1=a[1]&b[1];
g2=a[2]&b[02];
g3=a[3]&b[3];
assign
c1=g0|(p0&c0);
c2=g1|(p1&g0)|(p1&p0&c0);
c3=g2|(p2&g1)|(p2&p1&g0)|(p2&p1&p0&c0);
assign
sum[0]=p0^c0;
sum[1]=p1^c1;
sum[2]=p2^c2;
sum[3]=p3^c3;
c_4=c4
endmodule
```

**OUTPUT:** The Truth Table of CLA is verified

**Program 32**

**4.10 Write Verilog code to implement 4X4 Register Based Multiplier using RTL and Behavioral modeling**

**Aim:** Design 4X4 register based multiplier using RTL and Behavioral modeling

**Software Requirements:**

Synthesis tool:	Xilinx Project navigator – ISE 14.7
Simulation tool:	ModelSim Simulator

**Description:** Binary multiplication is based on the basic operations  $0 \times 0 = 0$  ;  $0 \times 1 = 0$ ;  $1 \times 0 = 0$ ;  $1 \times 1 = 1$ . Multiplication is by a factor of  $2^m$  can be accomplished using a ShL-m operations on a register.

While multiplying ‘n’ bits we specify a word of length of  $n=4$  with input values  $a = a_3a_2a_1a_0$  and  $b = b_3b_2b_1b_0$ . The product  $axb$  is given by 8 bit result

$$P = p_7p_6p_5p_4p_3p_2p_1p_0$$

Each bit ‘bi’ multiplies the multiplicand ‘a’ on a bit by bit basis.

$$P_i = \sum_{j+k=i} a_j b_k + C_{i-1}$$

RTL (Register transfer level) is step by step process which uses low level keywords, it uses assign as a keyword, Behavioral modeling is a architectural modeling .It is module based or object based.

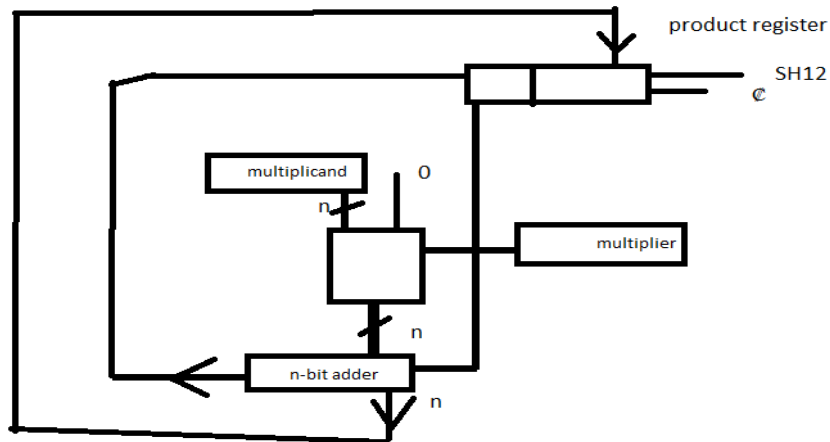

## RTL CODE

```

module regmul(a,b,p)
input[3:0] a,b ;
output[7:0 ] p;
Wire[7:0] w1,w2,w3,w4;
assign w1= a*b[0]*1;
assign w2= a*b[1]*2;
assign w3= a*b[2]*4;
assign w4= a*b[3]*8;
assign p= w1|w2|w3|w4;
endmodule
    
```

## BEHAVIOURAL CODE

```

module regmul(a,b,p)
input[3:0] a,b ;
output[7:0 ] p;
Wire[7:0] w1,w2,w3,w4;
Always @ (a & b )
begin
w1= a*b[0]*1;
w2= a*b[1]*2;
w3= a*b[2]*4;
w4= a*b[3]*8;
p= w1|w2|w3|w4;
end
endmodule
    
```



## Program 33

### Array Multiplier

4.11 **Aim** : implement Array multiplier Using RTL modeling

#### Software Requirements:

Synthesis tool:	Xilinx Project navigator – ISE 14.7
Simulation tool:	ModelSim Simulator

**Description:** An array multiplier accepts the multiplier and multiplicand which uses an array of cells to calculate the bit products of  $a_j b_k$  individually in parallel manner.

#### LOGIC SYMBOL

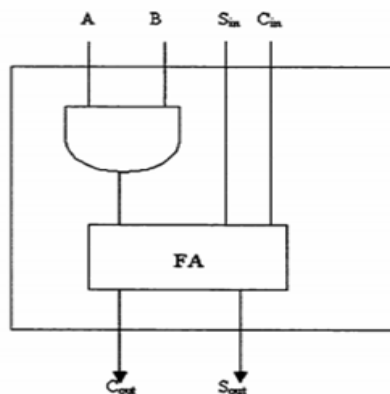

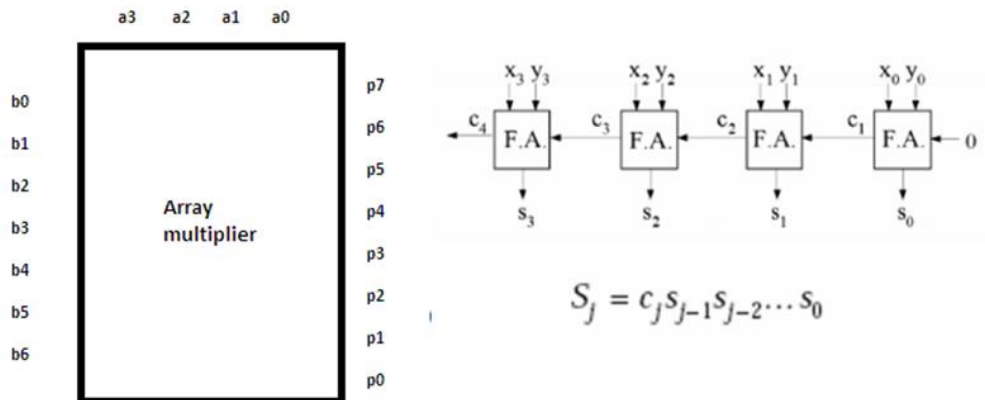

## LOGIC DIAGRAM

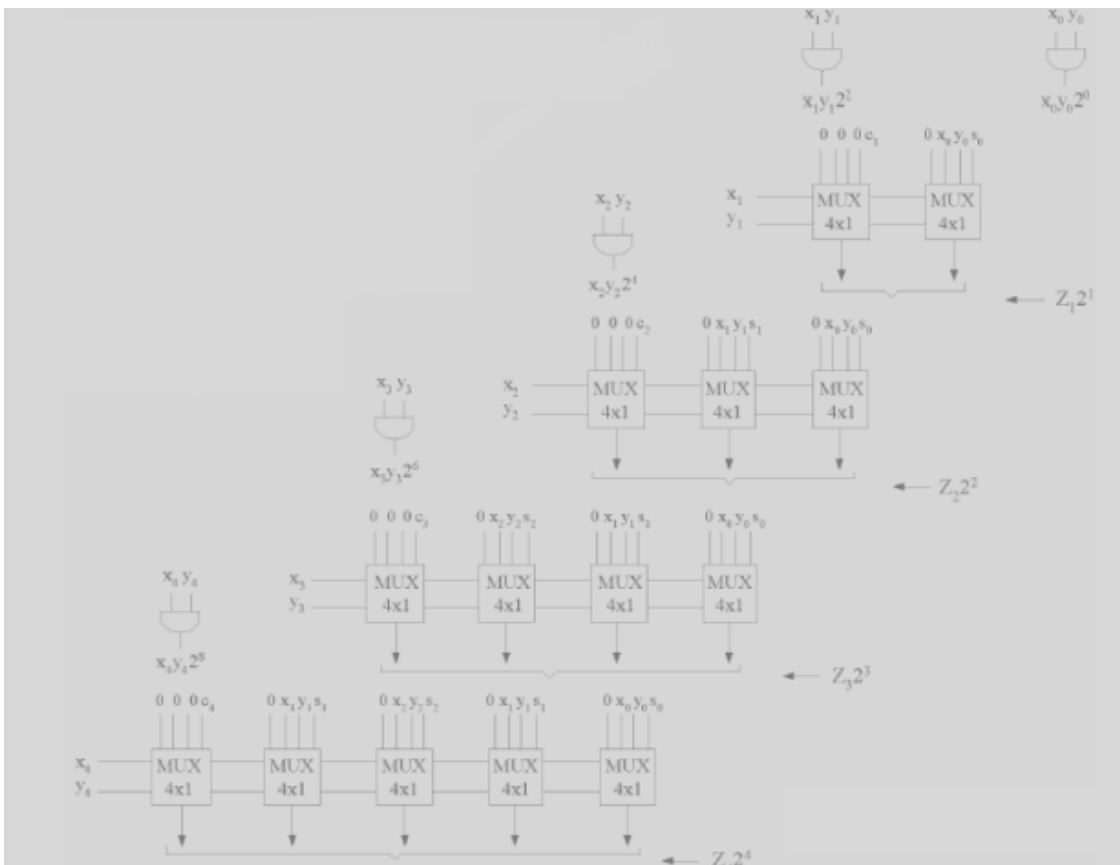

## RTL CODE

```

Module artl(a,b,p);
Input [3:0]a;
Input [3:0]b;

```

```
Output [7:0] p;
Wire w0,w1,w2,w3,w4,w5;
Wire[11:0] c;
Assign p[0]=a[0]&b[0];
Half n1 ((a[0]&b[1]),(a[1]&b[0]),p[1],c[0]);
Half n2 ((a[1]&b[1]),(a[2]&b[0]),w0,c[1]);
Assign{c[3],p[2]}=w0 + (a[0]&b[2]) +c[0];
Half n3 ((a[2]&b[1]),(a[3]&b[0]),w1,c[3]);
Assign{c[4],w2}=w1 + (a[1]&b[2]) +c[1];
Assign{c[5],p[3]}=w2 + (a[0]&b[3]) +c[2];
Assign{c[6],w3}= (a[3]&b[1]) +(a[2]&b[2]+c[3]);
Assign{c[7],w4}=w3 + c[4]+(a[1]&b[3]);
Half n4 (w4,c[5],p[4],c[8]);
Assign{c[10],p[5]}=w5+c[7]+c[8];
Assign{c[11],p[6]}=(a[3]&b[3])+c[9]+c[10];
Assign p[7]=c[11];
endmodule
```

### Behavioural Code

```
module abm(a,b,p)
input [3:0] a,b;
output[7:0] p; reg[7:0] p;
wire[7:0]w, reg wire [7:0] w;
always @ ( a & b)
begin
w1 = a * b [0] *1 ;
w1 = a * b [0] *1 ;
w2 = a * b [1] *2 ;
w1 = a * b [2] *4 ;
w1 = a * b [3] *8 ;
end
endmodule
```

## Program 34

### LAYOUT DESIGNING [DSCH2 & MICROWIND2]

#### Obtain Layout Design Of Not Gate In CMOS

**Aim:** Implement Layout Design Of Not Gate In CMOS

#### Software Requirements:

Synthesis tool:	Dsch 2
Simulation tool:	microwind 2

#### PROCEDURE:

1. Click on open tab of Dsch2, , inside the library create a New file name (Ex: xxx.sch).
2. Design the CMOS equivalent of an Inverter by dragging and dropping required symbol.
3. Click on file---> Make Verilog file .
4. Click on simulate tab ---→Start Simulate.
5. Open Microwind
6. Click on File---→xxx.sch file(created using DSch2)
7. Click on Compile tab ----→compile verilog file
8. Compile and close

**Program 34**

**Inverter(NOT)**

**CMOS DIAGRAM OF Inverter(NOT)**



# VLSI DESIGN LAB MANUAL

---

## LAYOUT OF NOT GATE

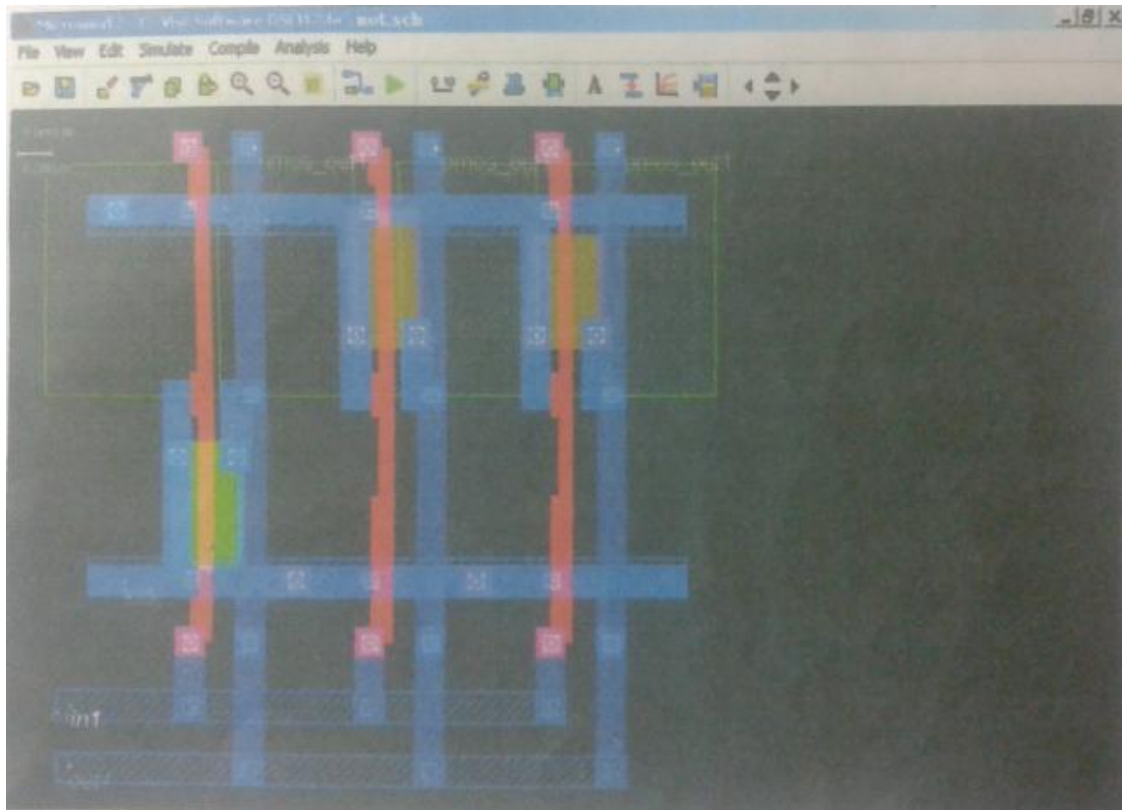

**Program 35**

**CMOS DIAGRAM FOR 2 INPUT NAND GATE**

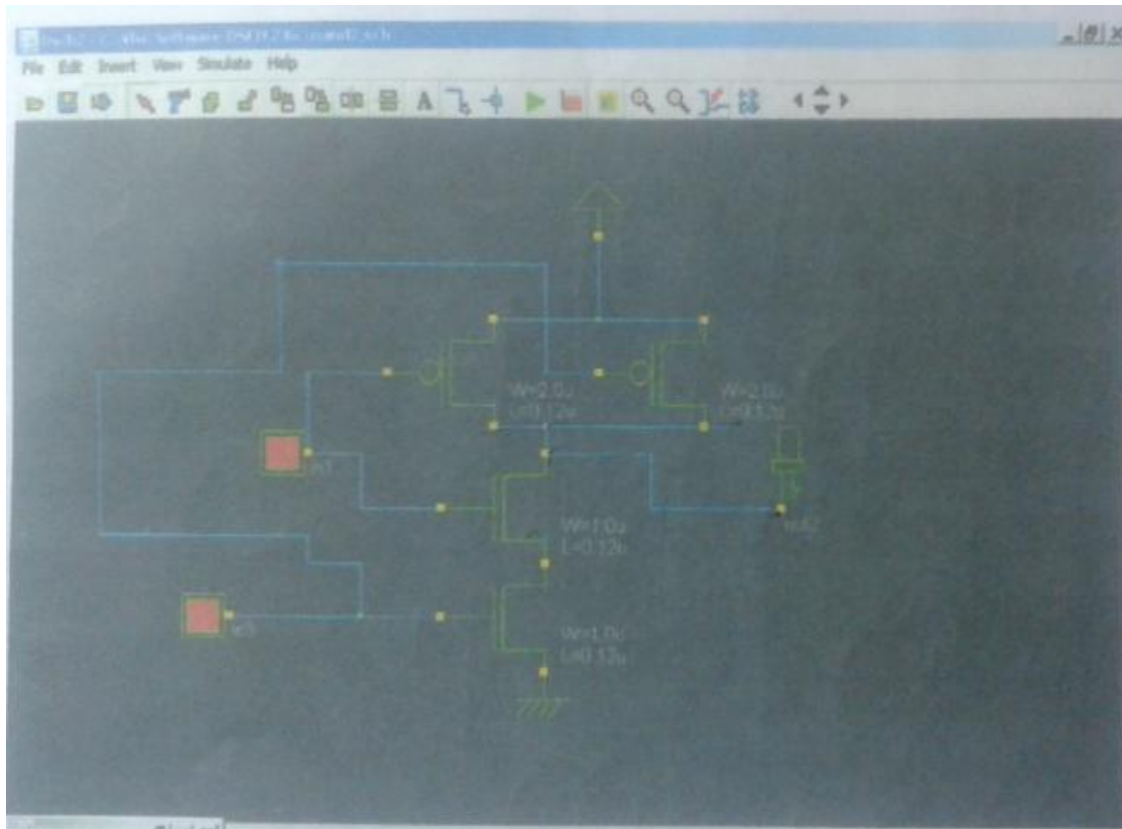

# VLSI DESIGN LAB MANUAL

## LAYOUT OF NAND GATE

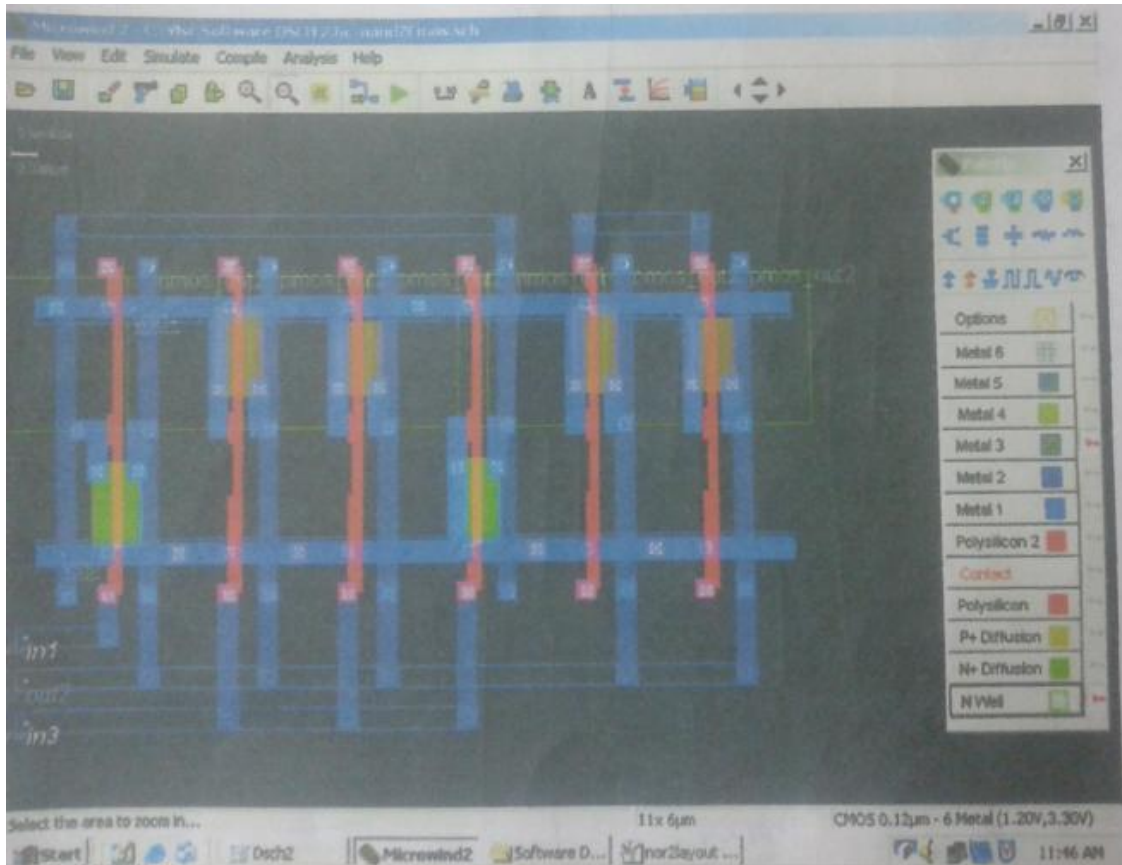



**Program 36**

**CMOS DIAGRAM OF NOR GATE**

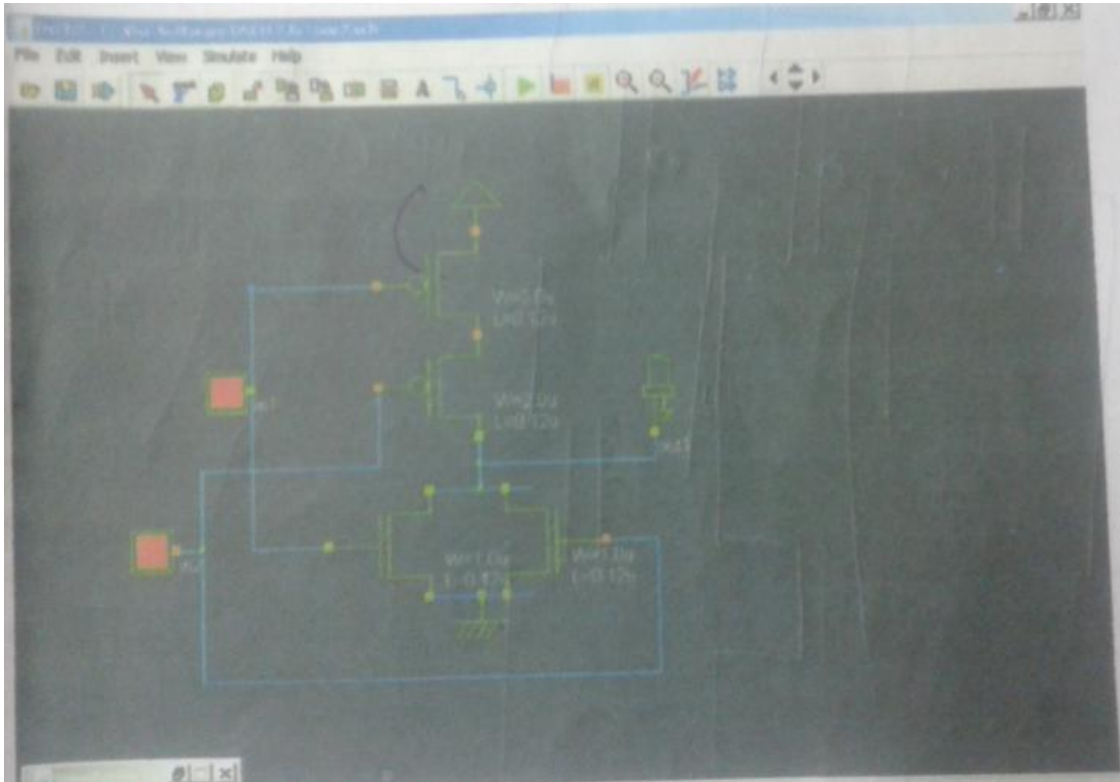

# VLSI DESIGN LAB MANUAL

## LAYOUT OF 2 INPUT NOR GATE

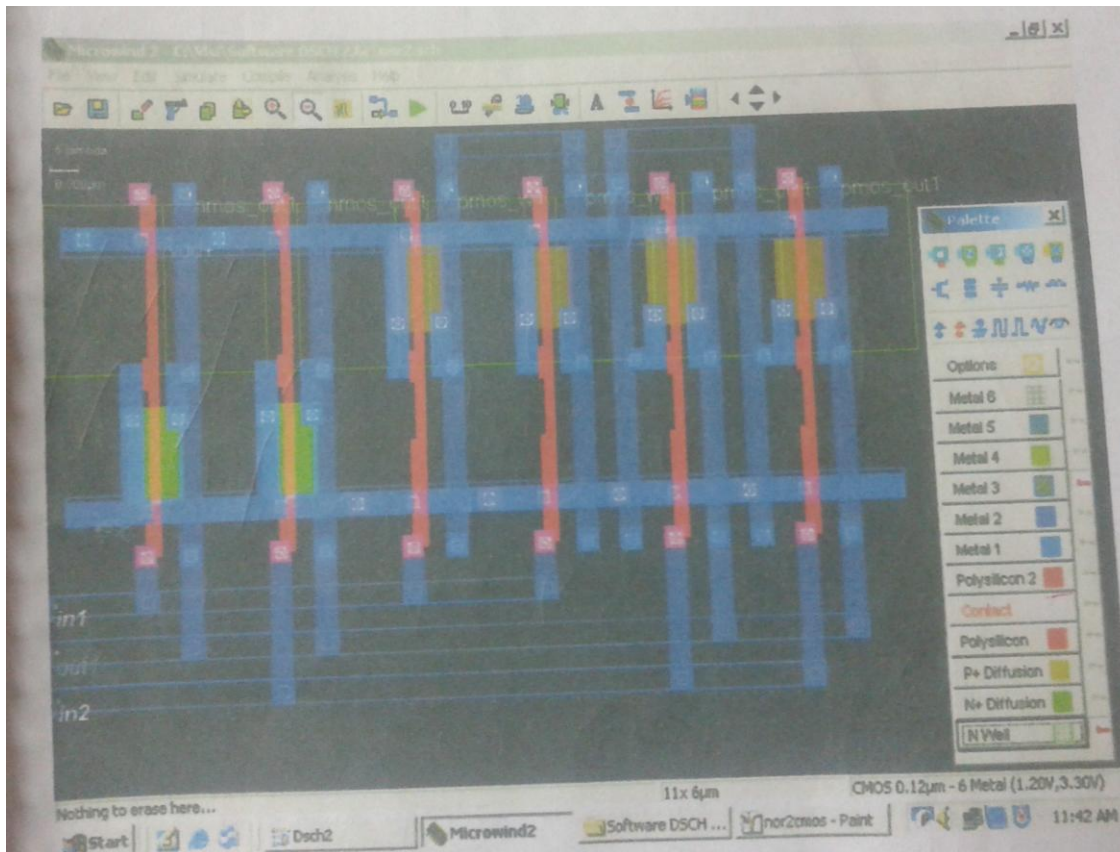

## Annexure – I

### List of programs according to O.U. curriculum

With Effect From the Academic Year 2013-14

BIT 431

#### VLSI DESIGN LAB

Instruction per week	4 Periods
Duration of University Examination	3Hours
University Examination	75Marks
Sessional	25 Marks

1. Switch level modeling using Verilog
  - a) Logic gates b) AOI and OAI gates
  - c) Transmission gate d) Complex logic gates using CMOS
2. Structural Gate-level Modeling [With and without delay]— Digital circuits using gate primitives—using Verilog.
  - a) AOI gate b) Half adder and full adders
  - c) MUX using buffers d) S-R latch etc.
3. Mixed gate —level and Switch-level modeling using Verilog-usage of primitives, modules and instancing and understanding the hierarchical design.
  - a) Constructing a 4-input AND gate using CMOS 2-input NAND and NOR gates.
  - b) Constructing a decoder using CMOS 2-input AND gates and NOT gates etc.
4. RTL Modeling of general VLSI system components.
  - a) MUXes b) Decoders c) Priority encodes d) Flip-flops e) Registers.
5. Synthesis of Digital Circuits
  - a) Ripple carry adder and carry look-ahead adder
  - b) array multiplier
6. Verilog code for finite state machine
7. Modeling of MOSFET
8. Stick diagram representations. Simple layout of Inverter. Understanding the concepts of Design Rule checking.
9. Fault Modeling for Stuck-at-O and Stuck-at-I faults.
10. Clock generation circuits (study)

## ANNEXURE -II

### MUFFAKHAM JAH COLLEGE OF ENGINEERING AND TECHNOLOGY LABORATORY COURSE EVALUATION SYSTEM PROGRAMMING LABORATORY COURSES

- i. The number of experiments/programs/sessions in each laboratory course shall be as per the curriculum in the scheme of instructions provided by OU.
- ii. The students will maintain a separate note book for each laboratory course in which all the related work would be done.
- iii. In each session the students will complete the assigned tasks of process development, coding, compiling, debugging, linking and executing the programs.
- iv. The students will then execute the programme and validate it by obtaining the correct output for the provided input. The course coordinator will certify the validation in the same session.
- v. The students will submit the record in the next class. The evaluation will be continuous and not cycle-wise or at semester end.
- vi. The internal marks of 25 are awarded in the following manner:
  - a. Laboratory record - Maximum Marks 15
  - b. Test and Viva Voce - Maximum Marks 10
- vii. Laboratory Record: Each experimental record is evaluated for a score of 50.  
**The rubric parameters are as follows:**
  - a. Write up format - Maximum Score 20
  - b. Process development and coding - Maximum Score 10
  - c. Compile, debug, link and execute program - Maximum Score 15
  - d. Process validation through input-output - Maximum Score 5

While (a) is assessed at the time of record submission, (b), (c) and (d) are assessed during the session based on the performance of the student in the laboratory session. Hence if a student is absent for any laboratory session but completes the program in another session and subsequently submits the record, it shall be evaluated for a score of 20 and not 50.

**viii.** The experiment evaluation rubric is therefore as follows :

Parameter	Max Score	Outstanding	Accomplished	Developing	Beginner	Points
Process Development and Coding	10					
Compilation, Debugging, Linking and Executing	15					
Process Validation	5					
Write up format	20					

**ix.** The first page of the record will contain the following title sheet:

# VLSI DESIGN LAB MANUAL

---

**MUFFAKHAM JAH COLLEGE OF ENGINEERING AND TECHNOLOGY**  
**LABORATORY EXPERIMENT ASSESSMENT SHEET**  
**INFORMATION TECHNOLOGY DEPARTMENT**  
**B.E. IV/IV I SEM**  
**VLSI DESIGN LABORATORY (BIT 431)**

**NAME:**

**ROLL NO.**

Exp. No.	Title of the Program	Date conducted	Date Submitted	Process Development and Coding (Max 10)	Compilation , Debugging, Linking and Executing (Max 15)	Process Validation (Max 5)	Write up format (Max 20)	Total Score (Max 50)
1								
2								
3								
4								
5								
6								
7								
8								
9								
10								
11								
12								
	<b>TOTAL</b>							

**Date:**  
**Coordinator**

**Signature of Course**

- x. The 15 marks of laboratory record will be scaled down from the TOTAL of the assessment sheet.
- xi. The test and viva voce will be scored for 10 marks as follows:

Internal Test	-	6 marks
Viva Voce / Quiz	-	4 marks
- xii. Each laboratory course shall have 5 course outcomes.

**The proposed course outcomes would be as follows:**

On successful completion of the course, the student will acquire the ability to:

1. Apply the design concepts for development of a process and interpret data
  2. Demonstrate knowledge of programming environment, compiling, debugging, linking and executing variety of programs.
  3. Demonstrate documentation and presentation of the algorithms / flowcharts / programs in a record form.
  4. Validate the process using known input-output parameters.
  5. Employ analytical and logical skills to solve real world problem and demonstrate oral communication skills.
- xiii. The Course coordinators would prepare the assessment matrix in accordance with the guidelines provided above for the five course outcomes. The scores to be entered against each of the course outcome would be the sum of the following as obtained from the assessment sheet in the record:
    - a. Course Outcome 1: Sum of the scores under 'Process Development and Coding'.
    - b. Course Outcome 2: Sum of the scores under 'Compilation/Debugging/Linking and Executing'.
    - c. Course Outcome 3: Sum of the scores under 'Write up format'.
    - d. Course Outcome 4: Sum of the scores under 'Process validation'.
    - e. Course Outcome 5: Marks for 'Internal Test and Viva voce'.
  - xiv. Soft copy of the assessment matrix would be provided to the course coordinators.

## LABORATORY EXPERIMENT EVALUATION RUBRIC

<b>CATEGORY</b>	<b>OUTSTANDING (Up to 100%)</b>	<b>ACCOMPLISHED (Up to 75%)</b>	<b>DEVELOPING (Up to 50%)</b>	<b>BEGINNER (Up to 25%)</b>
Write up format	Aim, Apparatus, material requirement, theoretical basis, procedure of experiment, sketch of the experimental setup etc. is demarcated and presented in clearly labeled and neatly organized sections.	The write up follows the specified format but a couple of the specified parameters are missing.	The report follows the specified format but a few of the formats are missing and the experimental sketch is not included in the report	The write up does not follow the specified format and the presentation is shabby.
Observations and Calculations	The experimental observations and calculations are recorded in neatly prepared table with correct units and significant figures. One sample calculation is explained by substitution of values	The experimental observations and calculations are recorded in neatly prepared table with correct units and significant figures but sample calculation is not shown	The experimental observations and calculations are recorded neatly but correct units and significant figures are not used. Sample calculation is also not shown	The experimental observations and results are recorded carelessly. Correct units significant figures are not followed and sample calculations not shown
Results and Graphs	Results obtained are correct within reasonable limits. Graphs are drawn neatly with labeling of the axes. Relevant calculations are performed from the graphs. Equations are obtained by regression analysis or curve fitting if relevant	Results obtained are correct within reasonable limits. Graphs are drawn neatly with labeling of the axes. Relevant calculations from the graphs are incomplete and equations are not obtained by regression analysis or curve fitting	Results obtained are correct within reasonable limits. Graphs are not drawn neatly and or labeling is not proper. No calculations are done from the graphs and equations are not obtained by regression analysis or curve fitting	Results obtained are not correct within reasonable limits. Graphs are not drawn neatly and or labeling is not proper. No calculations are done from the graphs and equations are not obtained by regression analysis or curve fitting
Discussion of results	All relevant points of the result are discussed and justified in light of theoretical expectations. Reasons for divergent results are identified and corrective measures discussed.	Results are discussed but no theoretical reference is mentioned. Divergent results are identified but no satisfactory reasoning is given for the same.	Discussion of results is incomplete and divergent results are not identified.	Neither relevant points of the results are discussed nor divergent results identified